



WILLIAMS[®]
FORM ENGINEERING CORP.



Concrete Forming Hardware Systems

For over 95 years

No. 321_{u1}



Using Williams Products

Readers of this catalog should independently verify the efficiency of any Williams products for the purpose intended by the user. The suitability of Williams products will depend upon field conditions, fabrications and user specifications which must be investigated and controlled by the user or its representatives. What follows are some suggestions for proper use of Williams products.

Proper Use is the Key

Williams Form Engineering Corporation provides a limited warranty on all of its products, as set forth in its quotations, acknowledgements and invoices furnished to each customer in connection with the sale of those products. Notwithstanding this limited warranty, you should be aware that Williams products are intended for use by qualified and experienced workers. Serious accidents may result from misuse or improper supervision or inspection. Carefully field test any use not strictly conforming to normal practice before general adoption of the application. Carefully evaluate the product application, determine safe working loads and control all field conditions to prevent unsafe load applications. All safety factors shown are approximate, and in no case should they be exceeded.

IMPROPER USE OR INSTALLATION MAY RESULT IN SERIOUS INJURY OR DEATH. IF YOU HAVE THE SLIGHTEST DOUBT CONCERNING PROPER USE OR INSTALLATION, PLEASE CONSULT WITH OUR ENGINEERING DEPARTMENT.

You are Responsible for Any Modifications or Substitutions

Do not weld any casting, unless in the opinion of a qualified engineer such weld is in a no load, non-critical area. Welding causes carbides and extreme brittleness near the weld point, and destroys nearly all load value. Any welding or modifications to Williams products are the responsibility of the user, and as set forth in its limited warranty, Williams Form Engineering Corporation makes no representations or warranties concerning products altered, welded, bent or modified by others.

Many Williams products are manufactured, supplied and or designed as a system. Hence, we cannot guarantee that components from systems supplied by other manufacturers are interchangeable with our products. For best results, all parts of a system should consist of Williams products. From time to time, Williams Form Engineering Corporation may change product designs, safe working load ratings and product dimensions without prior notice to users. For the most current information concerning Williams products, please contact our engineering department, one of our technical representatives or see our web site.

Ongoing Inspection and Replacement are Essential

Each user should periodically inspect bolts and working hardware for wear and discard worn parts. Bent bolts, and bolts used at loads exceeding advertised yield strength should be discarded and replaced. A comprehensive inspection and replacement program should be instituted and followed, so that all bolts will be replaced after a predetermined number of uses, regardless of the apparent condition of the bolt.

All lifting hardware units displayed in this catalog are subject to wear, misuse, overloading, corrosion, deformation and other factors which may affect their safe working load. They should be regularly inspected to see if they may be used at the rated safe working load or removed from service. Frequency of inspection is dependent upon frequency and period of use, environment and other factors, and is best determined by an experienced user taking into account the actual conditions under which the hardware is used.

Ordering Procedure and Warranties

This catalog is intended to provide potential purchasers and users with general information about products offered by Williams Form Engineering Corporation. Prices, specifications, product descriptions and catalog items are subject to modification without prior notice. Any person desiring further information about products offered by Williams Form Engineering Corporation may contact the company or its authorized representatives. In appropriate cases, Williams will provide quotations for possible orders.

Because the contents of this catalog are intended for general information purposes, they are subject to change without notice. Any warranties for Williams products shall be governed by Williams quotations, acknowledgements and invoices furnished to customers in connection with the sale of Williams products, as these documents contain more detail than this catalog. Williams Form Engineering Corporation disclaims all other warranties for its products, expressed or implied, including IMPLIED WARRANTIES OF MERCHANTABILITY AND FITNESS FOR A PARTICULAR PURPOSE, which might otherwise arise from the contents of this catalog.



Table of Contents

| | | | |
|--|-------|---|-------|
| Using Williams Products | 2 | Chapter 6: Miscellaneous Forming Accessories | |
| Table of Contents | 3 | Miscellaneous Forming Accessories | 38-39 |
| Chapter 1: General Form Design Data | | Chapter 7: Tie Rods & Accessories | |
| Types of Concrete Forming Systems | 4-5 | Coil & UNC Tie Rods | 40 |
| Rated Loads & Safety Factors | 6 | Tie Rod Accessories | 41 |
| Factors Affecting Lateral Pressure on Formwork | 7 | Chapter 8: Reinforcing Bar | |
| Lateral Pressure Values for Form Design | 8 | Grade 75 & Grade 80 All-Thread Rebar | 42-43 |
| Typical Tie Locations & Form Design | 9 | Grade 60 Rebar | 44 |
| Common Forming Lumber Properties | 10 | Grade 60 All-Thread Rebar | 45 |
| Safe Spacing of Supports | 11-12 | Rebar Bends | 46-47 |
| Chapter 2: Heavy Tie Thru Forming | | Rebar Connections | 48-50 |
| Shebolt Forming System | 13 | Plastic Rebar Supports | 51 |
| Tie-Rods & Accessories | 14 | Metal Rebar Supports | 52-53 |
| External Fasteners | 15 | Screeding | 54-55 |
| Taper Tie Forming System | 16-17 | Chapter 9: Bridge Beam Hangers | |
| Chapter 3: Heavy One Sided Forming | | Bridge Beam Hangers | 56-58 |
| Pigtail System | 18 | Chapter 10: Miscellaneous | |
| Cantilever Forming | 19 | Scaffolding & Shoring | 59 |
| Forming Off Steel | 20 | Concrete Anchors | 60-61 |
| Chapter 4: Ties and Inserts | | Project Photos | 62 |
| Coil Bolts & Accessories | 21 | Weights & Measures | 63 |
| Coil Ties | 22-23 | | |
| Coil Inserts | 24-26 | | |
| Ferrule Inserts | 27-29 | | |
| Chapter 5: Light Forming | | | |
| Panel Ties | 30-31 | | |
| Single Waler System | 32-33 | | |
| Single Waler Bracket Installation | 34-35 | | |
| Snapties | 36-37 | | |

Technical Assistance

Let Williams help save you thousands of dollars in start up costs by acting as an on-site advisor during your anchor bolt installation.

Our technician will work directly with your superintendent and crews to see they are prepared in terms of equipment needs, material coordination, and efficient installation procedures to yield the best productivity possible.

Our technicians are trained in most types of anchoring conditions and can often trim days off the bolting schedule by recommending efficient procedures. Technicians may also prove to be very beneficial in consulting with the design engineer to propose any last minute design changes to accommodate field conditions. Even the simplest anchoring job could have delays for an inexperienced crew. Take advantage of our expertise and be prepared to keep your project on schedule.

*Advance notification is requested. Contact your nearest Williams Representative for fee schedules.



Concrete Forming Hardware

One Sided Forming

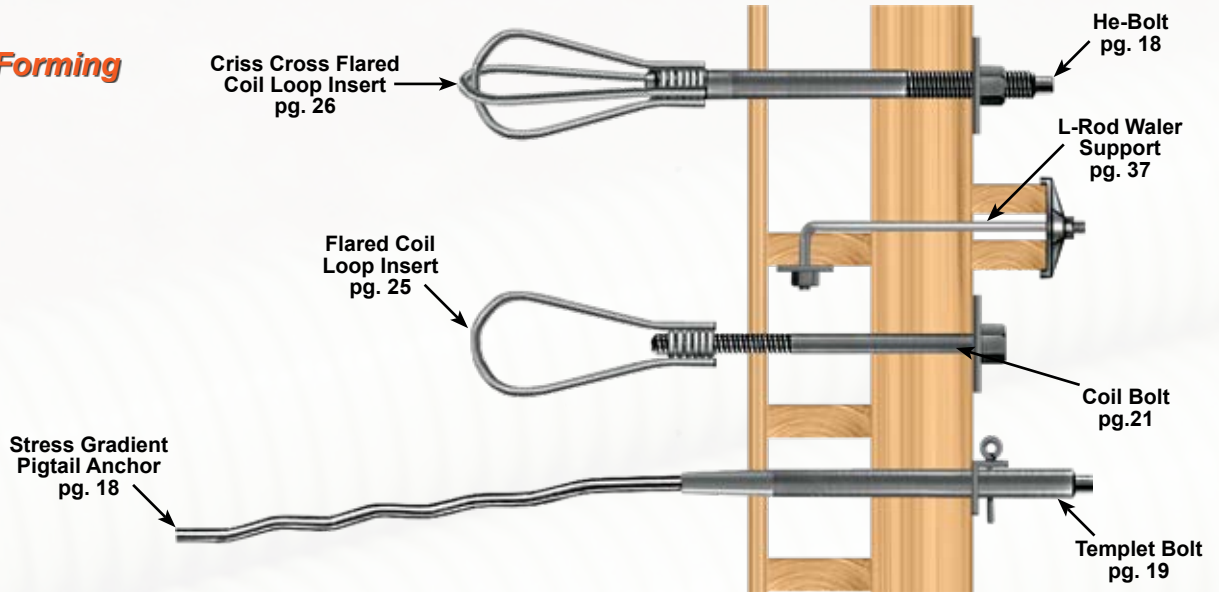

Light Tie Thru Forming

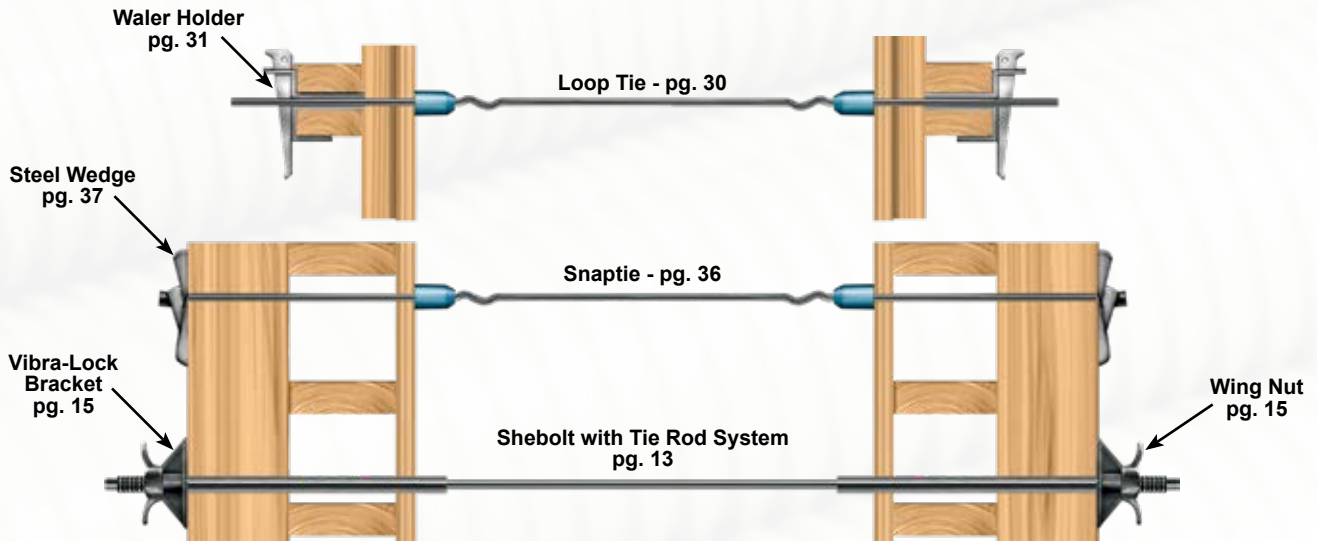

Heavy Tie Thru Forming

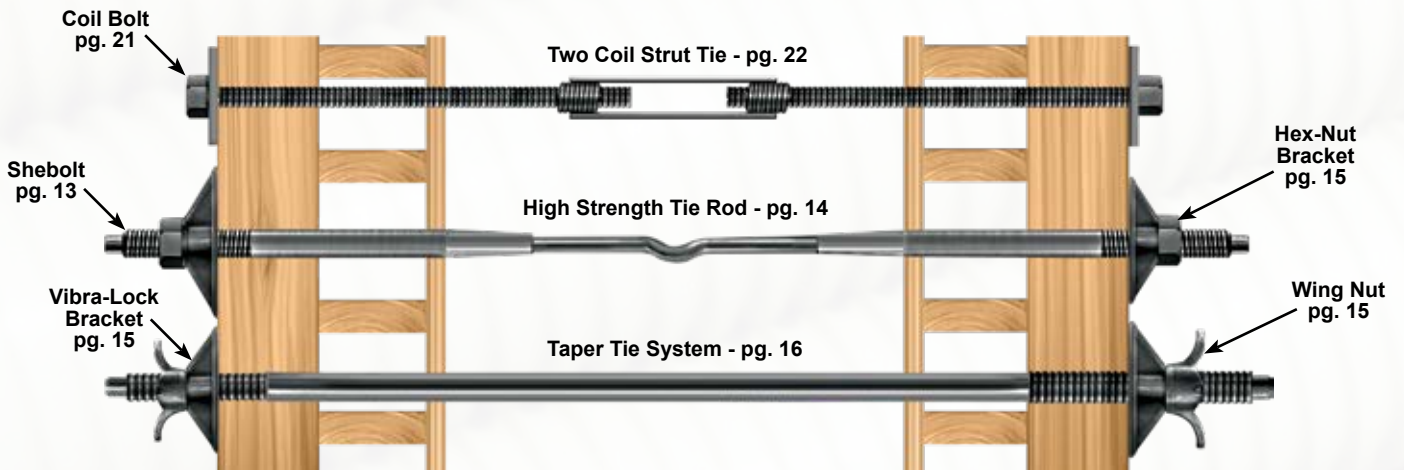



Forming off Rock & Concrete

Many of the forming products shown in this publication may be used with other Williams Form Engineering products which are shown in either our *Ground Engineering Systems (GES)* or our *High Capacity Concrete Anchor Systems (HCCA)* catalogs.

Forming Off Rock

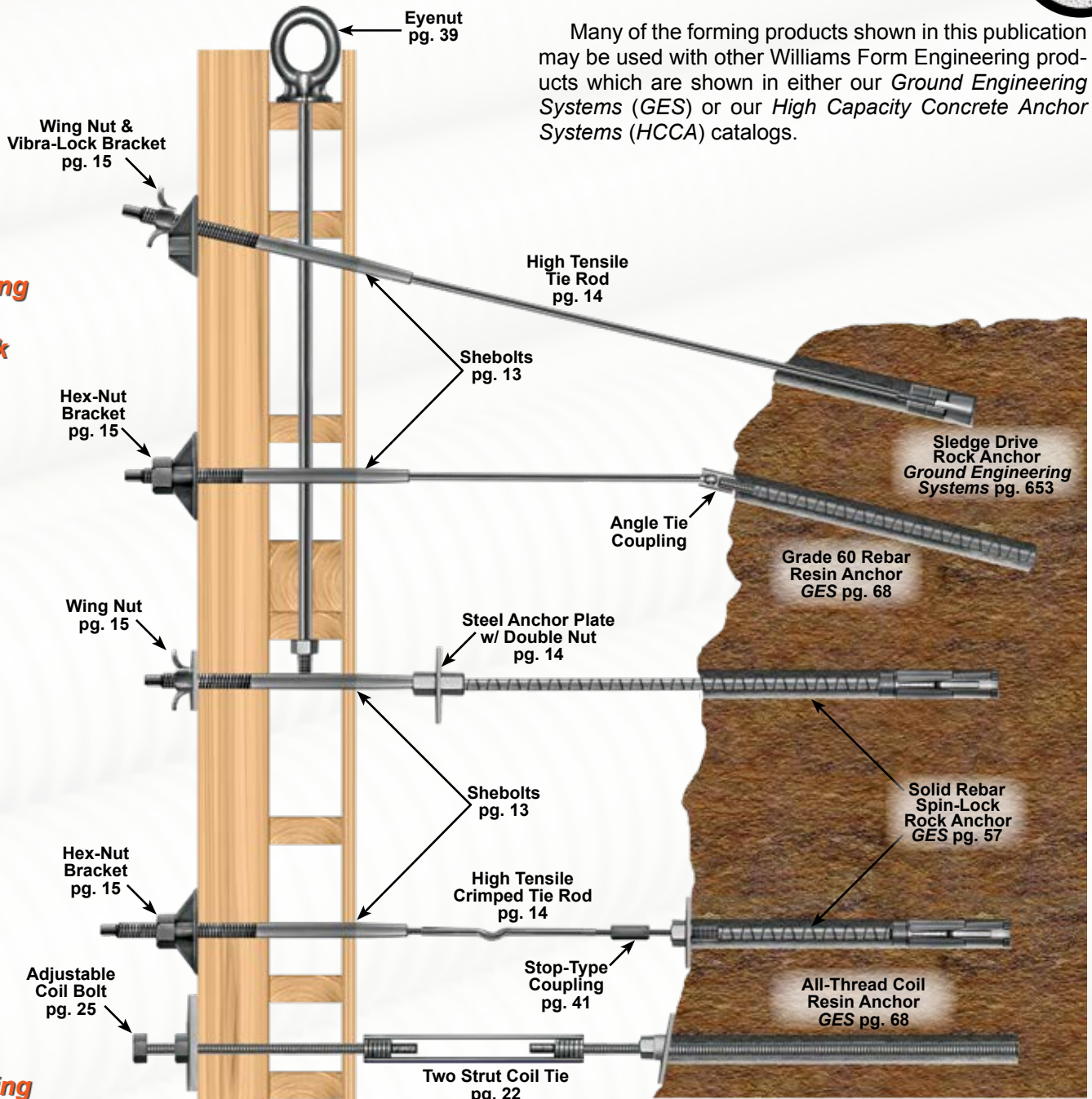

Forming Off Concrete

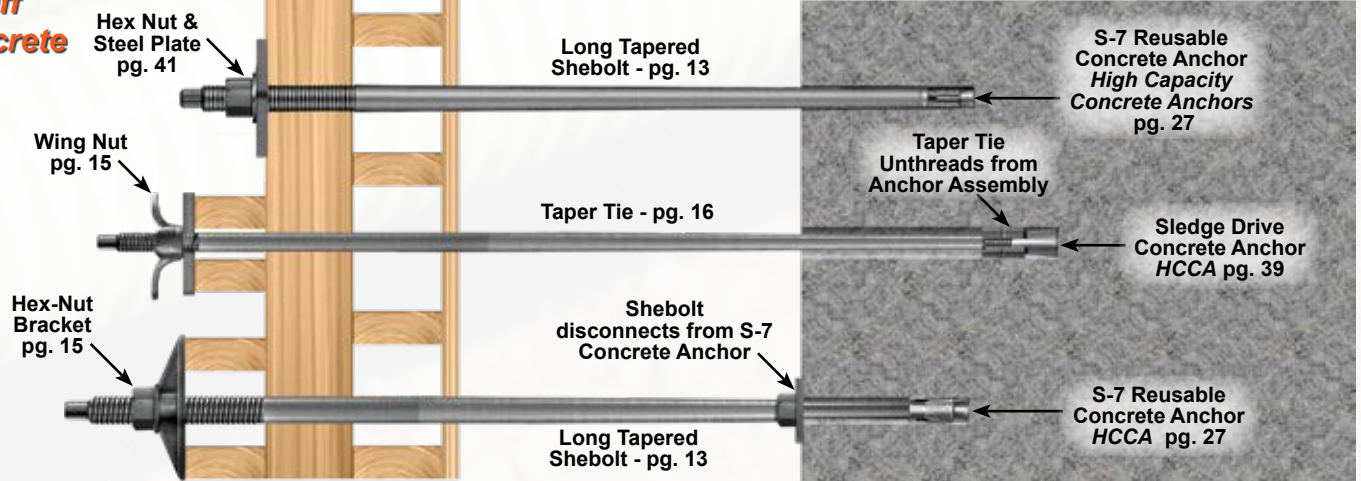



Rated Loads & Safety Factors

It is apparent from the table that the safety factor applied to a given product is a variable depending on the degree of hazard involved in the application of the product. The user of the products in this publication must determine the applicable safety factor for the products as a function of its use as described in the table.

Williams strongly advises that the safety factors shown in the Minimum Safety Factors of Formwork Accessories table be followed. If there are any unusual job site conditions, such as shock, impact, vibration, etc., safety factors must be increased to ensure worker protection.

| Accessory | Safety Factor | Type of Construction |
|-------------------------|---------------|---|
| Form Tie | 2:1 | All formwork |
| Form Hangers | 2:1 | Supporting form + concrete weight + live loads |
| Form Anchor | 2:1 | Supporting form weight and concrete pressure only |
| Form Anchor | 3:1 | Supporting form weight, concrete pressure, live loads and impact |
| Insert used as Form Tie | 2:1 | Precast concrete panels used as formwork, Heavy cantilever formwork |

Product load ratings are based on the ultimate strength of the metal. Safe working loads displayed in the publication are approximate minimum values. Due to the variety of applications, the responsibility of selecting appropriate safety factors is up to the user of the product. Any recalculation of safe working loads due to a change in the approximate minimum safety factor should include a careful analysis of all hardware used in the application and the anticipated concrete strength involved. If any doubt, contact a Williams representative for clarification.

Williams urges that the provisions of the Occupational Safety and Health Administration and "Building Code Requirements for Reinforced Concrete" (ACI 318) be followed by all persons and organizations designing in precast lifting inserts. We especially advise that the safety factors shown be adhered to. If there are unusual job conditions of shock, impact or vibration, safety factors should be increased.

Safety Factors on Inserts

ACI 318 and OSHA Part 1910 require that lifting inserts use fabrication, handling and erection of precast concrete elements have a safety factor of 4:1. Inserts normally used in precast operations are now shown in this catalog with a safe working load based on a safety factor of 4:1. Other inserts used in precast operation not showing a safe working load based on 4:1 safety factor must be re-evaluated by the user to permit a 4:1 safety factor. All inserts showing a 4:1 safety factor, have an approximate ultimate strength based on the mechanical strength of the strut wires and welds. The safety factor of 4 provides at least 100 percent impact possibilities during erection. The intent of this factor is to avoid a brittle failure of the insert. It is not intended that any additional safety factor or load factor be used.

There are several factors which will affect the performance of an insert. The safe working load ratings and safety factors which are shown on the following pages were established with the following considerations:

Tension

The safe working loads shown on the following charts are based on these conditions:

- The insert is embedded and completely surrounded in sound, uncracked concrete.
- Concrete compressive strength at time of loading is no less than that shown in charts.
- The insert is located at such distance, in relation to corners and edges, to allow the development of an adequate shear cone. Minimum edge distance for inserts in unreinforced panels and loaded axially are twice the length of insert or twice the panel thickness, whichever is greater.
- The tension load on the insert must be calculated to include the effects of both axial and transverse loads.
- The attachment bolt must be fully threaded into the insert and must extend at least 1-1/2 threads beyond the end of the coil.

Shear

It is our experience that inserts embedded in concrete do not fail in shear. Failure of the insert is generally due to failure of the concrete above an insert when in the edge of a panel, or due to tensile stresses from an application of transverse forces at a point some fixed distance from the face of the concrete.

The magnitude of these forces can be calculated and the values obtained must be added to the tension component to arrive at the total tension on the insert. The total tension must be the value used to properly select an insert.

For the unusual condition where pure shear loading must be considered, use the AISC allowable values in single shear for unfinished bolts which is 10,000 psi.

| Bolt Diameter | 1/2" | 5/8" | 3/4" | 7/8" | 1" | 1-1/4" | 1-1/2" |
|-----------------------|------|------|------|------|------|--------|--------|
| Allowable shear (lbs) | 1950 | 3060 | 4410 | 6010 | 7850 | 12270 | 17670 |

To safely and effectively achieve these values, edge and corner distances must be great enough to prevent concrete failure.

Dynamic Loads

All rated safe working loads and safety factors shown in this catalog are for "static" loading conditions. If shock, dynamic, or impact forces are anticipated, appropriate safety factors must be applied.

ACI 318 Building Code

Lifting devices shall have a capacity sufficient to support four times the appropriate portion of the member's dead weight. The inclination of the lifting force shall be considered.



Factors Affecting Lateral Pressure on Formwork

Tie Down Angle Pressures

Example: Tie load from pressures estimated at 400 lbs. tie on 40° angle - load increases 31%. (400 lbs. x 131% = 5240 lbs.) Actual estimated tie load is 5240 lbs.

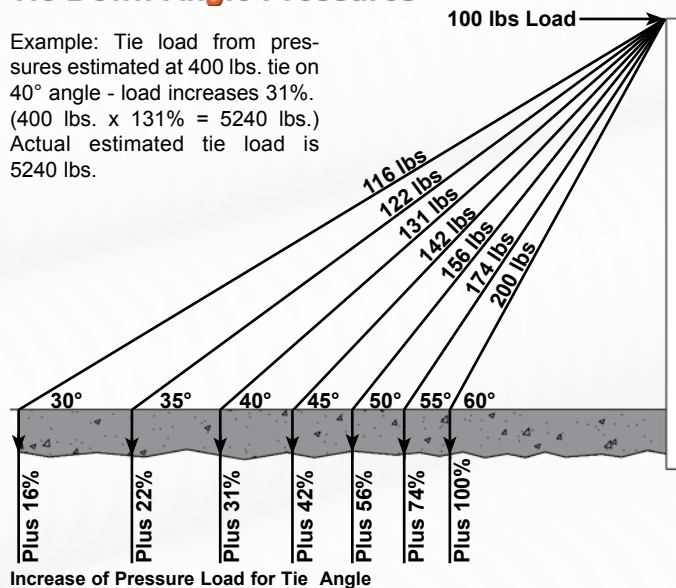

Shear Loads Induced by Tie-Down Rods

Note: Shebolt diameter and amount of preloading are important factors for carrying shear loads. If more than one Tie-Down Rod is used, total shear is the summation of shear induced by each rod.

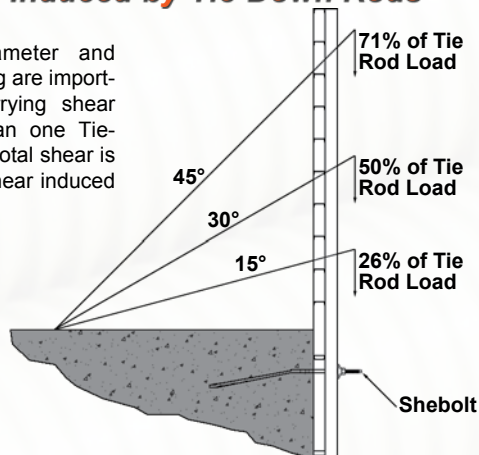

Weight of Concrete

The weight of concrete is a direct influence since hydrostatic pressure at any point in a fluid is created by the weight of the superimposed fluid. Liquid (hydrostatic) pressure is the same in all directions at a given depth in the fluid and acts at the right angles to any surface that confines it. If concrete acted as a true liquid, the pressure would be equal to the density of fluid times the depth, to the point at which the pressure was being considered. However, concrete is a mixture of solids and water whose behavior only approximates that of liquid for a limited time.

Rate of Placement

The average rate of rise of the concrete in the form is referred to as the rate of placement. The rate of placement has a primary effect on lateral pressure and the maximum lateral pressure is proportional to the rate of placement, up to a limit equal to the full fluid pressure. As the concrete is being placed, the lateral pressure at a given point increases as the concrete depth above the point increases. Finally, by consolidation and/or stiffening, the concrete will support itself and will no longer cause lateral pressure on the form.

Concrete Temperature

The temperature of the concrete at the time of placement has an important influence on pressure due to the affect it has on the setting time of the concrete. At lower concrete temperatures, the concrete takes longer to stiffen, so a greater depth of concrete can be placed before it becomes firm enough to be self-supporting. The greater liquid head results in higher lateral pressures. This is an important form design consideration when anticipating concrete placement in cold weather, with fly ash replacement or when using retarding admixtures.

Concrete Vibration

Internal vibration is a primary method of consolidating concrete in the form. It results in temporary, local lateral pressures that are 10 to 20 percent greater than those caused by simple spading. Since internal vibrating is an accepted common practice, forms should be designed to handle the added pressures.

Revibration and external vibration are the other types of vibration used in certain types of construction. Revibration and external vibration methods produce higher lateral loads than the internal vibration process and require specially designed forms. External vibration (also referred to as form vibration) is accomplished by attaching vibrators to the outside of the form. The form itself is vibrated to hammer the form against the concrete. The frequency/amplitude of external vibration must be regulated to consolidate the concrete but not too strong to damage the form. Revibration is the process where a vibrator is forced down through the upper placement into layers of concrete that have stiffened or have nearly reached initial set. Localized lateral pressures, up to 300 psf/ft of head of concrete, have been recorded using vigorous revibrations. Neither revibration nor external vibrations have been sufficiently investigated to be expressed in a standard formula. Pressure formulae in this publication are limited to concrete vibrated internally at the time of placement.

Other Variables

There are numerous other variables that will affect the lateral pressure in the form. Such things as the consistency of the concrete, the mount and location of reinforcing steel, ambient temperature, pour water pressure, aggregate size, placing procedures, type of cement, depth of placement, cross-section of the form, smoothness of the form faces and permeability of the form can all have an effect on the lateral pressure in the form. However, under normal conditions and forming practices, the range of these variable effects is generally small and is usually neglected.

On the other hand, the use of fly ash or other pozzolan as a cement replacement at low ambient temperatures or with a retarding mixture can have a significant effect on lateral pressure. Likewise, super-plasticizing admixtures and the retarders themselves can have a substantial effect on the lateral pressure. These conditions must be given due consideration during the form design process.



Lateral Pressure Values for Form Design

Vertical Wall Forms

The American Concrete Institute Committee 347 (Chapter 5) has developed the formulas below for maximum lateral pressure on the form, prescribed temperatures, rate of placement, vibration, concrete weight and slump. They are working formulas based on available data and are recommended for form design. No claim is made for their theoretical precision.

Walls with Rate of Placement (R) not exceeding 7 ft/hr:

$$p = 150 + \frac{9,000R}{T}$$

Maximum = 2,000 psf or 150h, whichever is less.

Walls with Rate of Placement (R) 7 to 10 ft/hr:

$$p = 150 + \frac{43,400R}{T} + \frac{2,800R}{T}$$

Maximum = 2,000 psf or 150h, whichever is less.

Walls with Rate of Placement (R) greater than 10 ft/hr:

$$p = 150h$$

Where:

p = maximum lateral pressure (psf)

R = rate of placement (ft/hr)

T = temperature of the concrete

h = maximum height of fresh concrete

The formulae are applicable for internally vibrated structural concrete of normal weight and density, produced with Type I cement and containing no pozzolans or admixtures and with a slump of less than four inches. Good concrete placing procedures are assumed; for example, vibration is used for consolidation only and is limited to four (4) feet below the surface of the concrete. The formulae assume that concrete "set" will occur as expected, usually in one hour. Don not use design pressures in excess of 150H. The table is based on Formulae 5-1 and 5-2. It shows the maximum lateral pressures to be used for form design for rates of placement up to 10 ft/hr and concrete temperatures from 40° to 90° F.

Since studs and sheathing are usually uniform throughout their height, only the maximum pressure value is required for their design. However, wales and tie spacing may be increased near the top of the form due to lower lateral pressure there.

Maximum Lateral Pressure for Design of Vertical Wall Forms

| Rate of Placement, R (ft per hr) | p, Maximum Lateral Pressure, psf, for Temperature Indicated | | | | | |
|----------------------------------|---|-------|-------|-------|-------|-------|
| | 90° F | 80° F | 70° F | 60° F | 50° F | 40° F |
| 2 | 600 | 600 | 600 | 600 | 600 | 600 |
| 3 | 600 | 600 | 600 | 600 | 690 | 825 |
| 4 | 600 | 600 | 664 | 750 | 870 | 1050 |
| 5 | 650 | 712 | 793 | 900 | 1050 | 1275 |
| 6 | 750 | 825 | 921 | 1050 | 1230 | 1500 |
| 7 | 850 | 938 | 1050 | 1200 | 1410 | 1725 |
| 8 | 881 | 973 | 1090 | 1246 | 1466 | 1795 |
| 9 | 912 | 1008 | 1130 | 1293 | 1522 | 1865 |
| 10 | 943 | 1043 | 1170 | 1340 | 1578 | 1935 |

Note: Do not use design pressures in excess of 150 x height of fresh concrete in forms.

A wall form 15' high may be concreted at R=10' per hour where the temperature is 60° F. Maximum pressure by Formula 5-2 or from Table above is 1340 psf. Since this is comparable to fluid pressure up to the time concrete begins to stiffen appreciably, any point within $1340/150 = 9'$ from the top of the form will have proportionately less pressure than the maximum. The 1340 maximum is used for design throughout the remaining 6' of the form.

Keep in mind that the pressure given in the formula (and shown in the drawing) represents an envelope of maximum pressure exerted during the total time required to fill the form. The diagram does not show distribution of pressure over the form surface at any one time.

In the case of a wall form only 6' high, concrete at the same R = 10' per hour and temperature of 60° F, the limit of 150 h applies since it is less than the value given by the formula. The envelope of maximum pressure then is as shown.

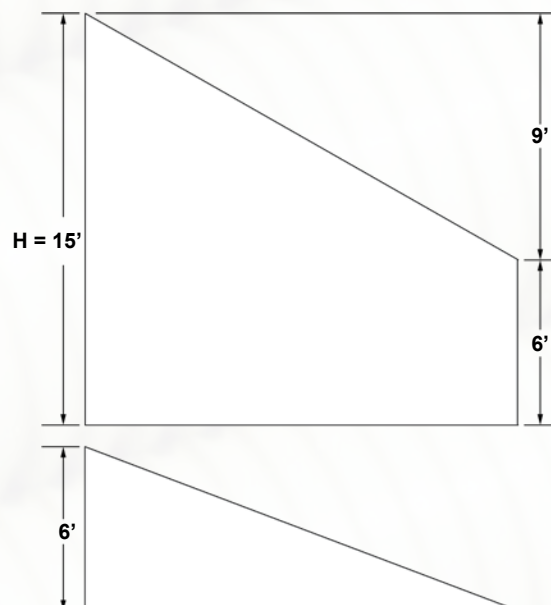



Typical Tie Locations and Form Design

Notes, Cautions and Warnings:

- If actual rate of placement exceeds design rate of placement, a snap tie or form failure may occur.
- If “set” time of concrete is altered by additives, i.e. entrained air, pozzolans, fly ash or other retarders, excess vibration or any other means of alterations or incorrect temperature allowances, then one of the lower row ties will likely fail due to an overload condition.
- Remember, a full liquid head of 150h can develop if concrete “set” does not occur when expected (or if concrete “set” is interrupted by excessive vibration). If, for example, a 12’ wall is poured in 3 hours at a rate of 4’ per hour design, and a form tie (or ties) fails, usually in the 2nd or 3rd row from the bottom, then the concrete probably did not “set” when expected, and a full or partial liquid head (150h) developed, causing much higher pressure than expected.

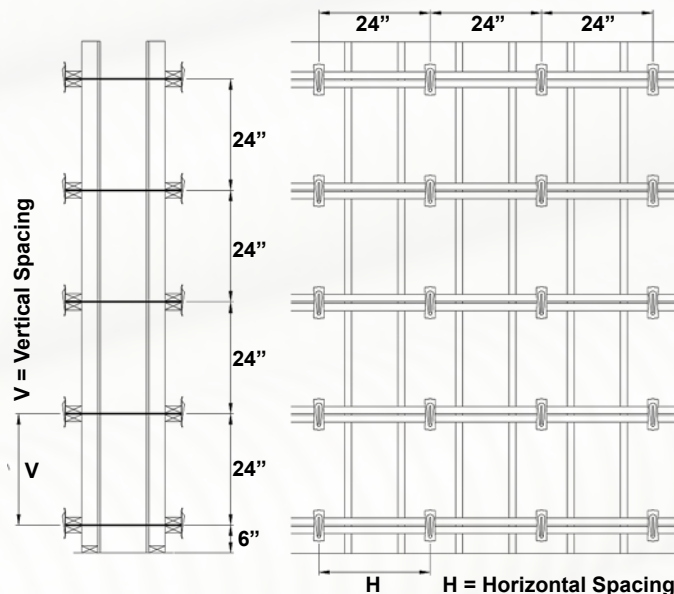

Note: Normal concrete, 150 lbs. Per cu. foot, without any additives, retarders or excessive vibration, at 70° F to 80° F will “set” in about 1-3/4 hours. It is possible for concrete “set” to take up to 3 hours under certain conditions. Forming contractors should exercise the utmost caution when evaluating expected “set” time. It is the least controllable of all parameters involved.

Caution:

It takes the concrete more than one hour to “set” under the following conditions:

- The addition of admixtures or pozzolans
- The addition of retarders or entrained air
- Actual temperature is less than design temperature
- Excessive vibration to depths greater than four feet below concrete surface
- Vibrator used to move concrete laterally in the form
- Revibration of prior vibrated areas
- Concrete slump in excess of four inches
- Use of cement other than Type I Portland Cement

Typical Location and Form Design - 2250 Lbs Safe Working Load Snap Ties

| Tie Spacing | | | Recommended Form Design | | | R = Rate of placement and ambient temperature (°F) | | | | | | Concrete Pressure | Actual Tie Load |
|--------------------|------------------|------------|----------------------------|--------------------------------|------------|--|-------|-------|-------|--------|-------|-------------------|-----------------|
| Horizontal Spacing | Vertical Spacing | Tie Area | Sheathing | Stud Size & Spacing | Wales | 40° | 50° | 60° | 70° | 80° | 90° | | |
| 2'-0" | 2'-0" | 4 sq ft | 5/8 Plyform 3/4 Plyform | 2x4 @ 11" c/c 2x4 @ 12" c/c | Dbl 2x4 | 1'-10" | 2'-3" | 2'-9" | 3'-2" | 3'-8" | 4'-2" | 562 lbs/sq ft | 2250 lbs |
| 2'-6" | 2'-0" | 5 sq ft | 5/8 Plyform 3/4 Plyform | 2x4 @ 12" c/c 2x4 @ 13" c/c | Dbl 2x4 | 1'-8" | 2'-0" | 2'-0" | 2'-4" | 2'-8" | 3'-0" | 450 lbs/sq ft | 2250 lbs |
| 2'-6" | 2'-6" | 6.25 sq ft | 5/8 Plyform 3/4 Plyform | 2x4 @ 13" c/c 2x4 @ 15" c/c | Dbl 2x4 | 0'-11" | 1'-2" | 1'-2" | 1'-7" | 1'-10" | 2'-1" | 360 lbs/sq ft | 2250 lbs |

Typical Location and Form Design - 3250 Lbs Safe Working Load Snap Ties

| Tie Spacing | | | Recommended Form Design | | | R = Rate of placement and ambient temperature (°F) | | | | | | Concrete Pressure | Actual Tie Load |
|--------------------|------------------|----------|----------------------------|--------------------------------|------------|--|-------|-------|--------|--------|--------|-------------------|-----------------|
| Horizontal Spacing | Vertical Spacing | Tie Area | Sheathing | Stud Size & Spacing | Wales | 40° | 50° | 60° | 70° | 80° | 90° | | |
| 2'-0" | 2'-0" | 4 sq ft | 5/8 Plyform 3/4 Plyform | 2x4 @ 9" c/c 2x4 @ 10" c/c | Dbl 2x4 | 2'-11" | 3'-8" | 4'-5" | 5'-1" | 5'-10" | 6'-7" | 812 lbs/sq ft | 3250 lbs |
| 2'-6" | 2'-6" | 5 sq ft | 5/8 Plyform 3/4 Plyform | 2x4 @ 10" c/c 2x4 @ 11" c/c | Dbl 2x4 | 2'-2" | 2'-9" | 3'-4" | 3'-10" | 4'-5" | 5'-0" | 650 lbs/sq ft | 3250 lbs |
| 3'-0" | 2'-0" | 6 sq ft | 5/8 Plyform 3/4 Plyform | 2x4 @ 11" c/c 2x4 @ 12" c/c | Dbl 3x4 | 1'-9" | 2'-2" | 2'-7" | 3'-0" | 3'-5" | 3'-11" | 542 lbs/sq ft | 3250 lbs |

Tables are based on a concrete “set” time of one hour. If “set” times of more than one hour are anticipated, adjust pour rates accordingly.



Common Forming Lumber Properties

Properties of Structural Lumber

| Nominal Size (in) b x h | American Standard Size (in) b x h S4S* 19% Maximum Moisture | Area of Section (in ²) A = bh | | Moment of Inertia (in) I = (bh ³) / 12 | | Section Modulus (in) S = (bh ²) / 6 | | Board Feet (per lineal ft of piece) | Approx. Weight (lbs per lineal ft)** |
|-------------------------|--|--|-------|---|--------|--|-------|-------------------------------------|--------------------------------------|
| | | Rough | S4S | Rough | S4S | Rough | S4S | | |
| 4 x 2 | 3-1/2 x 1-1/2 | 5.89 | 5.25 | 1.30 | 0.98 | 1.60 | 1.31 | 2/3 | 1.5 |
| 6 x 2 | 5-1/2 x 1-1/2 | 9.14 | 8.25 | 2.01 | 1.55 | 2.48 | 2.06 | 1 | 2.3 |
| 8 x 2 | 7-1/4 x 1-1/2 | 11.98 | 10.87 | 2.64 | 2.04 | 3.25 | 2.72 | 1-1/3 | 3.0 |
| 10 x 2 | 9-1/4 x 1-1/2 | 15.23 | 13.87 | 3.35 | 2.60 | 4.13 | 3.47 | 1-2/3 | 3.9 |
| 12 x 2 | 11-1/4 x 1-1/2 | 18.48 | 16.87 | 4.07 | 3.16 | 5.01 | 4.21 | 2 | 4.7 |
| 2 x 4 | 1-1/2 x 3-1/2 | 5.89 | 5.25 | 6.45 | 5.36 | 3.56 | 3.06 | 2/3 | 1.5 |
| 2 x 6 | 1-1/2 x 5-1/2 | 9.14 | 8.25 | 24.10 | 20.80 | 8.57 | 7.56 | 1 | 2.3 |
| 2 x 8 | 1-1/2 x 7-1/4 | 11.98 | 10.87 | 54.32 | 47.63 | 14.73 | 13.14 | 1-1/3 | 3.0 |
| 2 x 10 | 1-1/2 x 9-1/4 | 15.23 | 13.87 | 111.58 | 98.93 | 23.80 | 21.39 | 1-2/3 | 3.9 |
| 2 x 12 | 1-1/2 x 11-1/4 | 18.48 | 16.87 | 199.31 | 177.97 | 35.40 | 31.64 | 2 | 4.7 |
| 3 x 4 | 2-1/2 x 3-1/2 | 9.52 | 8.75 | 10.42 | 8.93 | 5.57 | 5.10 | 1 | 2.4 |
| 3 x 6 | 2-1/2 x 5-1/2 | 14.77 | 13.75 | 38.93 | 34.66 | 13.84 | 12.60 | 1-1/2 | 3.8 |
| 3 x 8 | 2-1/2 x 7-1/4 | 19.36 | 18.12 | 87.74 | 79.39 | 23.80 | 21.90 | 2 | 5.0 |
| 3 x 10 | 2-1/2 x 9-1/4 | 24.61 | 23.12 | 180.24 | 164.89 | 38.45 | 35.65 | 2-1/2 | 6.4 |
| 3 x 12 | 2-1/2 x 11-1/4 | 29.86 | 28.12 | 321.96 | 296.63 | 56.61 | 52.73 | 3 | 7.8 |
| 4 x 4 | 3-1/2 x 3-1/2 | 13.14 | 12.25 | 14.39 | 12.5 | 7.94 | 7.15 | 1-1/3 | 3.4 |
| 4 x 6 | 3-1/2 x 5-1/2 | 20.39 | 19.25 | 53.76 | 48.53 | 19.12 | 17.65 | 2 | 5.3 |
| 4 x 8 | 3-1/2 x 7-1/4 | 26.73 | 25.38 | 121.17 | 111.15 | 32.86 | 30.66 | 2-2/3 | 7.0 |
| 4 x 10 | 3-1/2 x 9-1/4 | 33.98 | 32.38 | 248.91 | 230.84 | 53.10 | 49.91 | 3-1/3 | 9.0 |

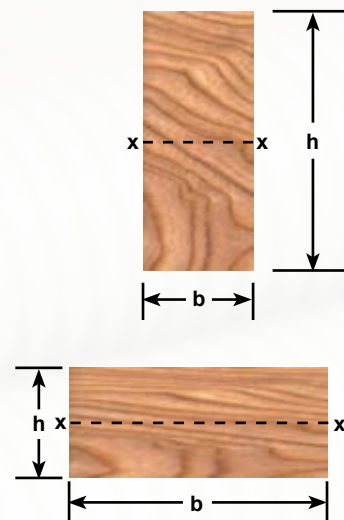

* Rough dry sizes are 1/8" larger, both dimensions.

** Based on a unit weight value of 40 lb. per cu ft. Actual weights vary depending on species and moisture content.

Data supplied by the National Forest Products Association

Form Loading in Pounds/ Sq. Foot for Incremental Slab Thickness*

| Concrete Weight (lbs per sq ft) | Slab Thickness | | | | | | | |
|---------------------------------|----------------|-----|-----|------|-----|-----|-----|-----|
| | 2" | 4" | 6" | 8 in | 10" | 12" | 14" | 16" |
| 100 | 67 | 84 | 100 | 117 | 134 | 150 | 167 | 184 |
| 115 | 70 | 89 | 108 | 127 | 146 | 165 | 185 | 204 |
| 125 | 71 | 92 | 113 | 134 | 155 | 175 | 196 | 217 |
| 135 | 73 | 95 | 118 | 140 | 163 | 185 | 208 | 230 |
| 150 | 75 | 100 | 125 | 150 | 175 | 200 | 225 | 250 |

* Values above include 50 psf live load for construction loads. Formwork dead load is not included.

Safe Spacing (ℓ) in inches of supports $\Delta_{max} = \ell / 360$, but not to exceed 1/16"

for plywood sheathing continuous over F = 72 psi

four or more supports. Table based on F = 1930 psi

APA rated plywood class 1. E = 1,500,000 psi

E = 1,650,000 psi

Safe Spacing of Supports for Plywood Sheathing

| Pressure or Load of Concrete (lbs per sq ft) | Sanded Thickness, Face Grain Parallel to Span | | | | Sanded Thickness, Face Grain Perpendicular to Span | | | |
|--|---|------|------|----|--|------|------|----|
| | 1/2" | 5/8" | 3/4" | 1" | 1/2" | 5/8" | 3/4" | 1" |
| 75 | 21 | 24 | 2 | 32 | 14 | 16 | 21 | 28 |
| 100 | 19 | 22 | 25 | 30 | 12 | 14 | 19 | 26 |
| 125 | 18 | 21 | 23 | 28 | 12 | 13 | 17 | 24 |
| 150 | 17 | 20 | 22 | 27 | 11 | 12 | 16 | 23 |
| 175 | 16 | 19 | 21 | 26 | 10 | 11 | 15 | 22 |
| 200 | 15 | 18 | 20 | 25 | 8 | 11 | 15 | 21 |
| 300 | 13 | 16 | 18 | 22 | 7 | 9 | 12 | 18 |
| 400 | 12 | 14 | 16 | 20 | 7 | 8 | 11 | 16 |
| 500 | 11 | 13 | 15 | 19 | 6 | 7 | 10 | 14 |
| 600 | 11 | 12 | 14 | 17 | 6 | 7 | 9 | 13 |
| 700 | 10 | 12 | 13 | 16 | 6 | 6 | 9 | 12 |
| 800 | 10 | 11 | 13 | 16 | 5 | 6 | 8 | 11 |
| 900 | 9 | 11 | 12 | 15 | 5 | 6 | 8 | 11 |
| 1000 | 9 | 10 | 12 | 14 | 5 | 5 | 7 | 10 |



Safe Spacing of Supports

Safe Spacing (ℓ) in inches of supports for joists, studs, etc. single span.

$$\Delta_{max} = \ell / 360, \text{ but not to exceed } 1/4''$$

$$E = 1,600,000 \text{ psi}$$

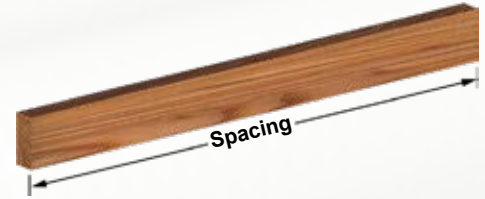

Safe Spacing of Supports - Simple Span Single-Ply Wales

| Uniform Load (lbs per lineal ft) | Nominal Size of S4S Lumber | 2x4 | 2x6 | 2x8 | 2x10 | 2x12 | 3x6 | 4x4 | 4x8 |
|--|-------------------------------|------|------|------|------|------|------|------|------|
| | Fb (psi) = | 1500 | 1250 | 1200 | 1050 | 975 | 1250 | 1500 | 1200 |
| 100 | | 60 | 94 | 115 | 138 | 160 | 106 | 80 | 142 |
| 200 | | 48 | 75 | 97 | 116 | 135 | 89 | 64 | 120 |
| 300 | | 42 | 61 | 79 | 94 | 111 | 78 | 55 | 108 |
| 400 | | 37 | 53 | 68 | 82 | 96 | 68 | 50 | 101 |
| 500 | | 33 | 47 | 61 | 73 | 86 | 61 | 47 | 93 |
| 600 | | 30 | 43 | 56 | 67 | 78 | 56 | 44 | 85 |
| 700 | | 28 | 40 | 51 | 62 | 72 | 51 | 42 | 79 |
| 800 | | 26 | 37 | 48 | 58 | 68 | 48 | 40 | 74 |
| 900 | | 24 | 35 | 45 | 54 | 64 | 45 | 37 | 70 |
| 1000 | | 23 | 33 | 43 | 51 | 60 | 43 | 35 | 66 |
| 1100 | | 22 | 32 | 41 | 49 | 58 | 41 | 34 | 63 |
| 1200 | | 21 | 30 | 39 | 47 | 55 | 39 | 32 | 60 |
| 1300 | | 20 | 29 | 38 | 45 | 53 | 38 | 31 | 58 |
| 1400 | | 19 | 28 | 36 | 43 | 51 | 36 | 30 | 56 |
| 1500 | | 19 | 27 | 35 | 42 | 49 | 35 | 29 | 54 |
| 1600 | | 18 | 26 | 34 | 41 | 48 | 34 | 28 | 52 |
| 1700 | | 17 | 25 | 33 | 39 | 46 | 33 | 27 | 50 |
| 1800 | | 17 | 25 | 32 | 38 | 45 | 32 | 26 | 49 |
| 1900 | | 17 | 24 | 31 | 37 | 44 | 31 | 26 | 48 |
| 2000 | | 16 | 23 | 30 | 36 | 43 | 30 | 25 | 46 |

All values below bold line indicate failure in bending.

Values are based on NDS 2001 for S.Y.P. #2

Safe Spacing (ℓ) in inches of supports for joists, studs, etc. continuous over three or more supports.

$$\Delta_{max} = \ell / 360, \text{ but not to exceed } 1/4''$$

$$E = 1,600,000 \text{ psi}$$

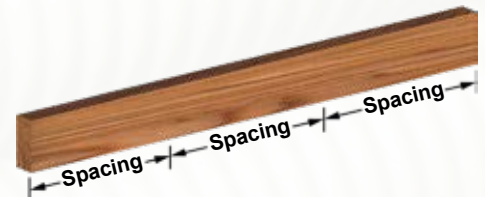

Safe Spacing of Supports - Multi-Span Single-Ply Wales

| Uniform Load (lbs per lineal ft) | Nominal Size of S4S Lumber | 2x4 | 2x6 | 2x8 | 2x10 | 2x12 | 3x6 | 4x4 | 4x8 |
|--|-------------------------------|------|------|------|------|------|------|------|------|
| | Fb (psi) = | 1500 | 1250 | 1200 | 1050 | 975 | 1250 | 1500 | 1200 |
| 100 | | 75 | 110 | 135 | 162 | 188 | 125 | 97 | 167 |
| 200 | | 58 | 84 | 108 | 129 | 152 | 105 | 79 | 140 |
| 300 | | 47 | 68 | 88 | 105 | 124 | 88 | 69 | 127 |
| 400 | | 41 | 59 | 76 | 91 | 107 | 76 | 62 | 117 |
| 500 | | 37 | 53 | 68 | 82 | 96 | 68 | 56 | 105 |
| 600 | | 33 | 48 | 62 | 74 | 87 | 62 | 51 | 95 |
| 700 | | 31 | 44 | 58 | 69 | 81 | 58 | 47 | 88 |
| 800 | | 29 | 42 | 54 | 64 | 76 | 54 | 44 | 83 |
| 900 | | 27 | 39 | 51 | 61 | 71 | 51 | 42 | 78 |
| 1000 | | 26 | 37 | 48 | 58 | 68 | 48 | 40 | 74 |
| 1100 | | 25 | 35 | 46 | 55 | 64 | 46 | 38 | 70 |
| 1200 | | 23 | 34 | 44 | 52 | 62 | 44 | 36 | 67 |
| 1300 | | 23 | 33 | 42 | 50 | 59 | 42 | 35 | 65 |
| 1400 | | 22 | 31 | 41 | 49 | 57 | 41 | 33 | 62 |
| 1500 | | 21 | 30 | 39 | 47 | 55 | 39 | 32 | 60 |
| 1600 | | 20 | 29 | 38 | 45 | 53 | 38 | 31 | 58 |
| 1700 | | 20 | 28 | 37 | 44 | 52 | 37 | 30 | 56 |
| 1800 | | 19 | 28 | 36 | 43 | 50 | 36 | 29 | 55 |
| 1900 | | 19 | 27 | 35 | 42 | 49 | 35 | 29 | 53 |
| 2000 | | 18 | 26 | 34 | 41 | 48 | 34 | 28 | 52 |

All values below bold line indicate failure in bending.

Values are based on NDS 2001 for S.Y.P. #2



Safe Spacing of Supports

Safe Spacing (ℓ) in inches of supports for double wales single span.

$\Delta_{max} = \ell / 360$, but not to exceed 1/4"
 $E = 1,600,000$ psi

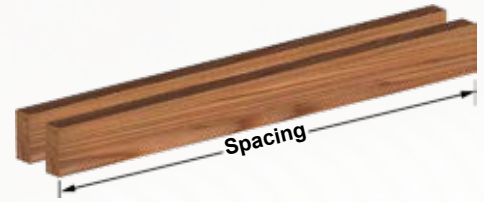

Safe Spacing of Supports - Simple Span Double-Ply Wales

| Uniform Load (lbs per lineal ft) | Nominal Size of S4S Lumber | 2x4 | 2x6 | 2x8 | 2x10 | 2x12 | 3x6 | 4x4 | 4x8 |
|--|-------------------------------|------|------|------|------|------|------|------|------|
| | Fb (psi) = | 1500 | 1250 | 1200 | 1050 | 975 | 1250 | 1500 | 1200 |
| 100 | | 76 | 111 | 137 | 164 | 190 | 126 | 98 | 169 |
| 200 | | 60 | 94 | 115 | 138 | 160 | 106 | 80 | 142 |
| 300 | | 53 | 83 | 104 | 125 | 145 | 96 | 70 | 129 |
| 400 | | 48 | 75 | 97 | 116 | 135 | 89 | 64 | 120 |
| 500 | | 44 | 67 | 86 | 103 | 121 | 83 | 59 | 113 |
| 600 | | 42 | 61 | 79 | 94 | 111 | 78 | 55 | 108 |
| 700 | | 39 | 56 | 73 | 87 | 102 | 73 | 53 | 104 |
| 800 | | 37 | 53 | 68 | 82 | 96 | 68 | 50 | 101 |
| 900 | | 34 | 50 | 64 | 77 | 90 | 64 | 48 | 98 |
| 1000 | | 33 | 47 | 61 | 73 | 86 | 61 | 47 | 93 |
| 1100 | | 31 | 45 | 58 | 70 | 82 | 58 | 45 | 89 |
| 1200 | | 30 | 43 | 56 | 67 | 78 | 56 | 44 | 85 |
| 1300 | | 29 | 41 | 53 | 6 | 75 | 53 | 43 | 82 |
| 1400 | | 28 | 40 | 51 | 62 | 72 | 51 | 42 | 79 |
| 1500 | | 27 | 38 | 50 | 59 | 70 | 50 | 41 | 76 |
| 1600 | | 26 | 3 | 48 | 58 | 68 | 48 | 40 | 74 |
| 1700 | | 25 | 36 | 47 | 56 | 65 | 47 | 38 | 72 |
| 1800 | | 24 | 35 | 45 | 54 | 64 | 45 | 37 | 70 |
| 1900 | | 24 | 34 | 44 | 53 | 62 | 44 | 36 | 68 |
| 2000 | | 23 | 33 | 43 | 51 | 60 | 43 | 35 | 66 |

All values below bold line indicate failure in bending.

Values are based on NDS 2001 for S.Y.P. #2

Safe Spacing (ℓ) in inches of supports for double wales continuous over three or more supports.

$\Delta_{max} = \ell / 360$, but not to exceed 1/4"
 $E = 1,600,000$ psi

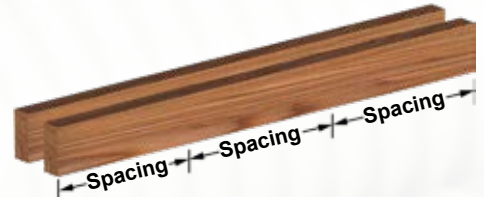

Safe Spacing of Supports - Multi-Span Double-Ply Wales

| Uniform Load (lbs per lineal ft) | Nominal Size of S4S Lumber | 2x4 | 2x6 | 2x8 | 2x10 | 2x12 | 3x6 | 4x4 | 4x8 |
|--|-------------------------------|------|------|------|------|------|------|------|------|
| | Fb (psi) = | 1500 | 1250 | 1200 | 1050 | 975 | 1250 | 1500 | 1200 |
| 100 | | 93 | 130 | 161 | 193 | 223 | 148 | 115 | 198 |
| 200 | | 75 | 110 | 135 | 162 | 188 | 125 | 97 | 167 |
| 300 | | 65 | 97 | 122 | 146 | 170 | 113 | 86 | 151 |
| 400 | | 58 | 84 | 108 | 129 | 152 | 105 | 79 | 140 |
| 500 | | 52 | 75 | 97 | 116 | 136 | 97 | 73 | 133 |
| 600 | | 47 | 68 | 88 | 105 | 124 | 88 | 69 | 127 |
| 700 | | 44 | 63 | 82 | 98 | 114 | 82 | 65 | 122 |
| 800 | | 41 | 59 | 76 | 91 | 107 | 76 | 62 | 117 |
| 900 | | 39 | 56 | 72 | 86 | 101 | 72 | 59 | 110 |
| 1000 | | 37 | 53 | 68 | 82 | 96 | 68 | 56 | 105 |
| 1100 | | 35 | 50 | 65 | 78 | 91 | 65 | 54 | 100 |
| 1200 | | 33 | 48 | 62 | 74 | 87 | 62 | 51 | 95 |
| 1300 | | 32 | 46 | 60 | 71 | 84 | 60 | 49 | 92 |
| 1400 | | 31 | 45 | 58 | 69 | 81 | 58 | 47 | 88 |
| 1500 | | 30 | 43 | 56 | 67 | 78 | 56 | 46 | 85 |
| 1600 | | 29 | 42 | 54 | 64 | 76 | 54 | 44 | 83 |
| 1700 | | 28 | 40 | 52 | 62 | 72 | 52 | 43 | 80 |
| 1800 | | 27 | 39 | 51 | 61 | 71 | 51 | 42 | 78 |
| 1900 | | 26 | 38 | 49 | 59 | 69 | 49 | 41 | 76 |
| 2000 | | 26 | 37 | 48 | 58 | 68 | 48 | 40 | 74 |

All values below bold line indicate failure in bending.

Values are based on NDS 2001 for S.Y.P. #2



Shebolt Tie-Rod Forming System

Quality, cold finished Shebolts are tapped with coil or V-thread inside and acme or coil thread outside. The tapped ends are countersunk for easy engagement and all edges are turned, reducing possible damage and prolonging life. For external spacing, Williams Shebolts are supplied with cross-drilled holes through the shank and an optional stop-pin can be placed inside the tapped end for controlling exact engagement and easy breakout.

Williams Shebolts can also be used with brackets for bracing, jacking and hanging forms, etc. Shebolts should be properly lubricated before inserting into the form, and should be checked periodically for wear.

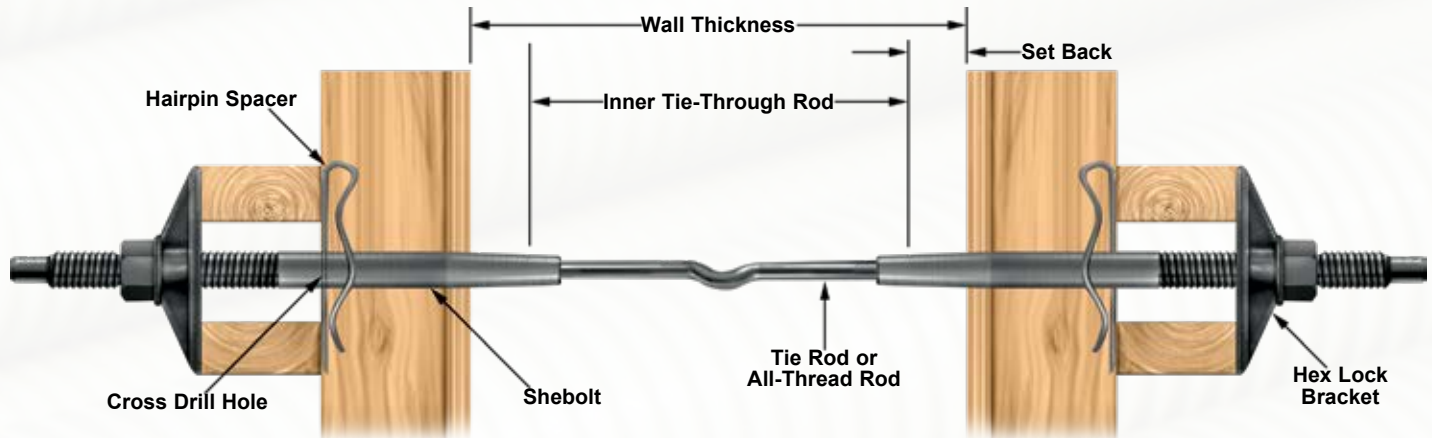

C5T Threaded Shebolt

| Shebolt Diameter | Maximum Tap Size | Standard Lengths | Thread Lengths | Weight | Wing Nuts | Vibra-Lock Bracket | Hex-Nut Bracket |
|---------------------|-------------------|---------------------------|--------------------------|-----------------------------------|-----------------|--------------------|-----------------|
| 9/16" (14 mm) | 3/8" (9.5 mm) | 16"; 18" (406; 457 mm) | 5"; 8" (127; 203 mm) | 0.94; 1.06 lbs (0.43; 0.48 kg) | W1 | B2 | Hex Nut & Plate |
| 3/4" * (19 mm) | 1/2" (13 mm) | 20"; 24" (508; 610 mm) | 9"; 12" (229; 305 mm) | 2.04; 2.40 lbs (0.93; 1.09 kg) | W3 | B3 | BR10 |
| 7/8" * (22 mm) | 1/2" (13 mm) | 20"; 24" (508; 610 mm) | 9"; 12" (229; 305 mm) | 2.72; 3.26 lbs (1.23; 1.48 kg) | W5 | B6 | BR15S |
| 1" * (25 mm) | 5/8" (16 mm) | 20"; 24" (508; 610 mm) | 9"; 12" (229; 305 mm) | 3.75; 4.63 lbs (1.7; 2.1 kg) | W5 | B6 | BR15S |
| 1-1/8" (29 mm) | 3/4" (19 mm) | 20"; 24" (508; 610 mm) | 9"; 12" (229; 305 mm) | 4.56; 5.69 lbs (2.07; 2.58 kg) | W6T | B8 | BR15S |
| 1-1/4" * (32 mm) | 3/4" (19 mm) | 20"; 24" (508; 610 mm) | 9"; 12" (229; 305 mm) | 5.94; 7.13 lbs (2.69; 3.23 kg) | W6T | B8 | BR21 |
| 1-3/8" (35 mm) | 7/8" (22 mm) | 24"; 30" (610; 762 mm) | 12" (305 mm) | 8.56; 10.7 lbs (3.88; 4.84 kg) | W6T | Hex Nut & Plate | BR21 |
| 1-1/2" * (38 mm) | 1" (25 mm) | 24"; 30" (610; 762 mm) | 12" (305 mm) | 9.88; 12.3 lbs (4.48; 5.58 kg) | W11 | Hex Nut & Plate | Hex Nut & Plate |
| 1-5/8" (41 mm) | 1" (25 mm) | As Specified | As Specified | As Specified | W11 | Hex Nut & Plate | Hex Nut & Plate |
| 1-3/4" (45 mm) | 1-1/8" (29 mm) | As Specified | As Specified | As Specified | Hex Nut & Plate | Hex Nut & Plate | Hex Nut & Plate |
| 2" (51 mm) | 1-1/4" (32 mm) | As Specified | As Specified | As Specified | Hex Nut & Plate | Hex Nut & Plate | Hex Nut & Plate |

* Standard sizes - coil outer thread, coil tap.

Shebolt diameters 9/16", 1-3/8", 1-5/8", 1-3/4", and 2" are available with acme outer thread.

External Spacing

Positive External Spacing is a patented design available only on Williams Shebolts. An optional stop pin can be factory placed in the tapped end of the Shebolt to assure when the unit is assembled, each tie will turn into the Shebolt the same distance. This means the distance between the cross drill holes in each Shebolt will be equal for every unit using the same length tie rod. When the unit is placed through the form (which may already have both sides standing) the hairpin spacer is placed through the cross drill hole, spacing the walers at every tie. The brackets are then placed on the Shebolt against the walers. A key factor in the external spacing system is the waler support, which is attached to a few studs and performs the task of locking the form together with the already spaced walers. Together the system eliminates the need for any internal cones, washers or wooden spacers.



Tie-Rods & Accessories

Williams High Tensile Tie Rods are available with "V"-Thread (Unified National Coarse) or Coil Threads in all diameters shown, with lengths from 3" to 20'-0". They are available all-threaded, thread one end, or threaded both ends. Short length tie rods threaded both ends under 2'-0" are usually crimped to prevent rotation in the concrete during removal of the Shebolt. Ties threaded each end allow easy spot-checking of the connection, to insure proper engagement.



B7S Coil Threaded Tie Rods

ASTM A108 Grade C1045

| Bar Diameter & Pitch | Minimum Net Area Thru Threads | Minimum Ultimate Strength | Minimum Yield Strength | Part Number |
|------------------------|---|---------------------------|------------------------|-------------|
| 3/8" - 8 (9.5 mm) | 0.08 in ² (50 mm ²) | 9.3 kips (41 kN) | 7.1 kips (32 kN) | B7S-03 |
| 1/2" - 6 (13 mm) | 0.14 in ² (91 mm ²) | 17 kips (75 kN) | 13 kips (58 kN) | B7S-04 |
| 5/8" - 4-1/2 (16 mm) | 0.22 in ² (143 mm ²) | 27 kips (118 kN) | 20 kips (90 kN) | B7S-05 |
| 3/4" - 4-1/2 (19 mm) | 0.33 in ² (215 mm ²) | 40 kips (178 kN) | 31 kips (136 kN) | B7S-06 |
| 7/8" - 4-1/2 (22 mm) | 0.46 in ² (296 mm ²) | 55 kips (245 kN) | 42 kips (187 kN) | B7S-07 |
| 1" - 3-1/2 (25 mm) | 0.59 in ² (381 mm ²) | 71 kips (315 kN) | 54 kips (241 kN) | B7S-08 |
| 1-1/8" - 3-1/2 (28 mm) | 0.74 in ² (477 mm ²) | 78 kips (345 kN) | 60 kips (266 kN) | B7S-09 |
| 1-1/4" - 3-1/2 (32 mm) | 0.97 in ² (625 mm ²) | 102 kips (453 kN) | 79 kips (349 kN) | B7S-10 |
| 1-1/2" - 3-1/2 (38 mm) | 1.47 in ² (951 mm ²) | 155 kips (689 kN) | 119 kips (531 kN) | B7S-12 |



B8S UNC Threaded Tie Rods

ASTM A108 Grade C1045

| Bar Diameter & Pitch | Minimum Net Area Thru Threads | Minimum Ultimate Strength | Minimum Yield Strength | Part Number |
|----------------------|--|---------------------------|------------------------|-------------|
| 3/8" - 16 (9.5 mm) | 0.08 in ² (50 mm ²) | 9.3 kips (41 kN) | 7.1 kips (32 kN) | B8S-03 |
| 1/2" - 13 (13 mm) | 0.14 in ² (92 mm ²) | 17 kips (76 kN) | 13 kips (58 kN) | B8S-04 |
| 5/8" - 11 (16 mm) | 0.23 in ² (146 mm ²) | 27 kips (121 kN) | 21 kips (93 kN) | B8S-05 |
| 3/4" - 10 (19 mm) | 0.33 in ² (216 mm ²) | 40 kips (178 kN) | 31 kips (137 kN) | B8S-06 |
| 7/8" - 9 (22 mm) | 0.46 in ² (298 mm ²) | 55 kips (247 kN) | 43 kips (189 kN) | B8S-07 |
| 1" - 8 (25 mm) | 0.61 in ² (391 mm ²) | 73 kips (324 kN) | 56 kips (248 kN) | B8S-08 |
| 1-1/8" - 7 (35 mm) | 0.76 in ² (492 mm ²) | 80 kips (356 kN) | 62 kips (275 kN) | B8S-09 |
| 1-1/4" - 7 (32 mm) | 0.97 in ² (625 mm ²) | 102 kips (453 kN) | 79 kips (349 kN) | B8S-10 |
| 1-3/8" - 8 (35 mm) | 1.23 in ² (794 mm ²) | 129 kips (575 kN) | 100 kips (443 kN) | B8S-11 |
| 1-1/2" - 6 (38 mm) | 1.41 in ² (906 mm ²) | 148 kips (656 kN) | 114 kips (506 kN) | B8S-12 |
| 1-3/4" - 5 (45 mm) | 1.90 in ² (1226 mm ²) | 200 kips (887 kN) | 154 kips (685 kN) | B8S-14 |
| 2" - 6 (51 mm) | 2.65 in ² (1710 mm ²) | 278 kips (1238 kN) | 215 kips (955 kN) | B8S-16 |



B7G Mild Steel Coil Rod

ASTM A108 Grade C1018

Williams B7G Coil Rod is manufactured in mild steel. It is available all-threaded or with threaded ends. The product can be welded. Standard lengths are 12' and 20'.

| Bar Diameter & Pitch | Minimum Net Area Thru Threads | Minimum Ultimate Strength | Minimum Yield Strength | Part Number |
|------------------------|--|---------------------------|------------------------|-------------|
| 1/2" - 6 (13 mm) | 0.14 in ² (90.9 mm ²) | 9.9 kips (44 kN) | 8.5 kips (38 kN) | B7G-04 |
| 3/4" - 4-1/2 (19 mm) | 0.33 in ² (215 mm ²) | 23 kips (104 kN) | 20 kips (89 kN) | B7G-06 |
| 1" - 3-1/2 (25 mm) | 0.59 in ² (381 mm ²) | 41 kips (184 kN) | 35 kips (158 kN) | B7G-08 |
| 1-1/4" - 3-1/2 (32 mm) | 0.97 in ² (625 mm ²) | 68 kips (302 kN) | 58 kips (259 kN) | B7G-10 |
| 1-1/2" - 3-1/2 (38 mm) | 1.47 in ² (951 mm ²) | 103 kips (459 kN) | 88 kips (393 kN) | B7G-12 |

S1K Steel Plates

Williams steel plates are standard with a round hole for Shebolts. All holes are punched 1/16" over bolt size. Any size plate is available.

| Thickness | Dimensions |
|--------------|------------------------|
| 1/2" (13 mm) | 4" x 4" (102 x 102 mm) |
| 1/2" (13 mm) | 6" x 6" (152 x 152 mm) |
| 3/4" (19 mm) | 6" x 6" (152 x 152 mm) |
| 3/4" (19 mm) | 8" x 8" (203 x 203 mm) |
| 1" (25 mm) | 6" x 6" (152 x 152 mm) |
| 1" (25 mm) | 8" x 8" (203 x 203 mm) |

C2T Stop-Type Coupling

The Stop-Type Coupling is a full strength component designed to assure exact engagement on both rods. They are available in UNC or Coil Thread. See pages 40-41 for more information.

R9F Hardened Washers

Williams carries standard cut washers in diameters of 3/8" to 3/4". The R9F hardened washers are recommended for high torquing or high load application. See pages 40-41 for more information.

H1F Hex Nuts & B25 Heavy Hex Nuts

Williams H1F UNC Thread Hex Nuts are hardened, pattern heavy nuts designed to hold the full strength of the bar. The H1F Standard Coil Hex Nuts are available to match any Williams coil rods. Two coil nuts are recommended for assurance of a full ultimate strength. Williams also offers a B25 Heavy Duty Coil Nuts which is recommended when assurance of ultimate strength capabilities are required with only one nut. See page 40-41 for more information.



External Fasteners

D6M Weighted Wing Nut

Williams special design wing nut is weighted on one side to prevent spin-off due to vibration during concrete placement. The built-in self-cleaning feature cleans concrete and debris from the Shebolt thread during removal. Available in acme or coil thread.



| Shebolt Diameter | Wing Nuts | Length | Diameter | Weight |
|-------------------|-----------|--------------------|---------------------|-----------------------|
| 9/16" (14 mm) | W1 | 5" (127 mm) | 13/16" (21 mm) | 0.31 lbs (0.14 kg) |
| 3/4" (19 mm) | W3 | 4-3/4" (121 mm) | 3/4" (19 mm) | 0.44 lbs (0.2 kg) |
| 1" (25 mm) | W5 | 5-3/8" (137 mm) | 1" (25 mm) | 0.69 lbs (0.3 kg) |
| 1-1/8" (29 mm) | W5T | 5-1/2" (140 mm) | 1-1/8" (29 mm) | 1.13 lbs (0.5 kg) |
| 1-1/4" (32 mm) | W6T | 5-1/2" (140 mm) | 1-1/8" (29 mm) | 1.13 lbs (0.5 kg) |
| 1-3/8" (35 mm) | W6T | 5-1/2" (140 mm) | 1-1/8" (29 mm) | 1.13 lbs (0.5 kg) |
| 1-1/2" (38 mm) | W11 | 6-1/2" (165 mm) | 1-25/32" (45 mm) | 2.25 lbs (1.0 kg) |
| 1-5/8" (41 mm) | W11 | 6-1/2" (165 mm) | 1-25/32" (45 mm) | 2.25 lbs (1.0 kg) |

D5M Vibra-Lock Bracket

Heavy-duty malleable brackets are battered on one side for angle tying up to 45°. The one-sided batter also prevents loosening of the bracket from shear loading. Webbed design allows for high strength usage. Rounded corners offer easy, safe handling.



| Shebolt Diameter | Vibra-Lock Bracket | Width | Length | Depth | Weight |
|-------------------|--------------------|---------------------|--------------------|-------------------|----------------------|
| 9/16" (14 mm) | B2 | 3-1/2" (88.9 mm) | 5" (127 mm) | 1-3/8" (35 mm) | 1.53 lbs (0.7 kg) |
| 3/4" (19 mm) | B3 | 4" (102 mm) | 5" (127 mm) | 1-1/8" (29 mm) | 2.00 lbs (0.9 kg) |
| 1" (25 mm) | B6 | 5-1/4" (133 mm) | 6-1/4" (159 mm) | 1-7/8" (48 mm) | 3.93 lbs (1.8 kg) |
| 1-1/8" (29 mm) | B8 | 6" (152 mm) | 7" (178 mm) | 1-7/8" (48 mm) | 4.72 lbs (2.1 kg) |
| 1-1/4" (32 mm) | B8 | 6" (152 mm) | 7" (178 mm) | 1-7/8" (48 mm) | 4.72 lbs (2.1 kg) |

D3M Hex-Nut Bracket

Heavy-duty malleable circular bracket offers easy, safe one-piece handling. Webbed design allows for high strength usage. The Hex-Nut Brackets' one-piece design offers solution to low or no access areas for tie through situations where pre attachment to forms and stripping is needed without prior removal of brackets.



| Shebolt Diameter | Hex-Nut Bracket | Diameter | Depth | Weight |
|-------------------|-----------------|--------------------|-----------------------|-----------------------|
| 3/4" (19 mm) | BR10 | 4-1/4" (108 mm) | 1-5/16" (33.3 mm) | 1.25 lbs (0.57 kg) |
| 7/8" (22 mm) | BR15S | 5" (127 mm) | 1-23/32" (43.7 mm) | 2.05 lbs (0.93 kg) |
| 1" (25 mm) | BR15S | 5" (127 mm) | 1-23/32" (43.7 mm) | 2.05 lbs (0.93 kg) |
| 1-1/8" (29 mm) | BR15S | 5" (127 mm) | 1-23/32" (43.7 mm) | 2.05 lbs (0.93 kg) |
| 1-1/4" (32 mm) | BR21 | 5" (127 mm) | 2-1/16" (52.4 mm) | 3.56 lbs (1.62 kg) |
| 1-3/8" (35 mm) | BR21 | 5" (127 mm) | 2-1/16" (52.4 mm) | 3.56 lbs (1.62 kg) |



Heavy Tie Thru Forming

Taper Tie Forming System

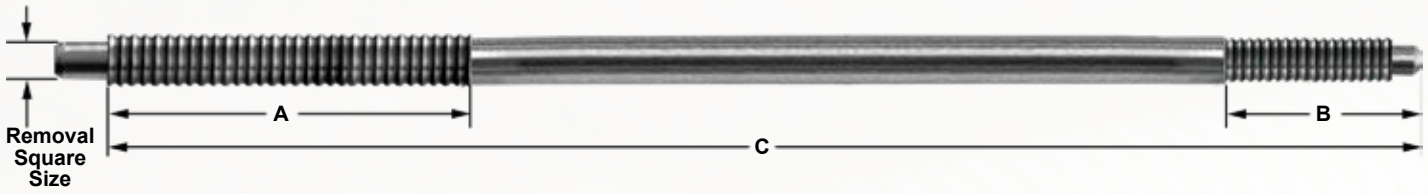

Williams Taper Tie System consists of totally reusable hardware. The one piece Taper Tie is ideal because of its fast assembly and easy strip feature. The adaptability of the Taper Tie to varying wall thickness makes it economically ideal. Available with varying degrees of taper. Taper Ties should be properly lubricated before inserting into the form. Taper Ties should be checked periodically for wear, and cleaned immediately after use. A special dome on the small end protects the threads from hammer blows.

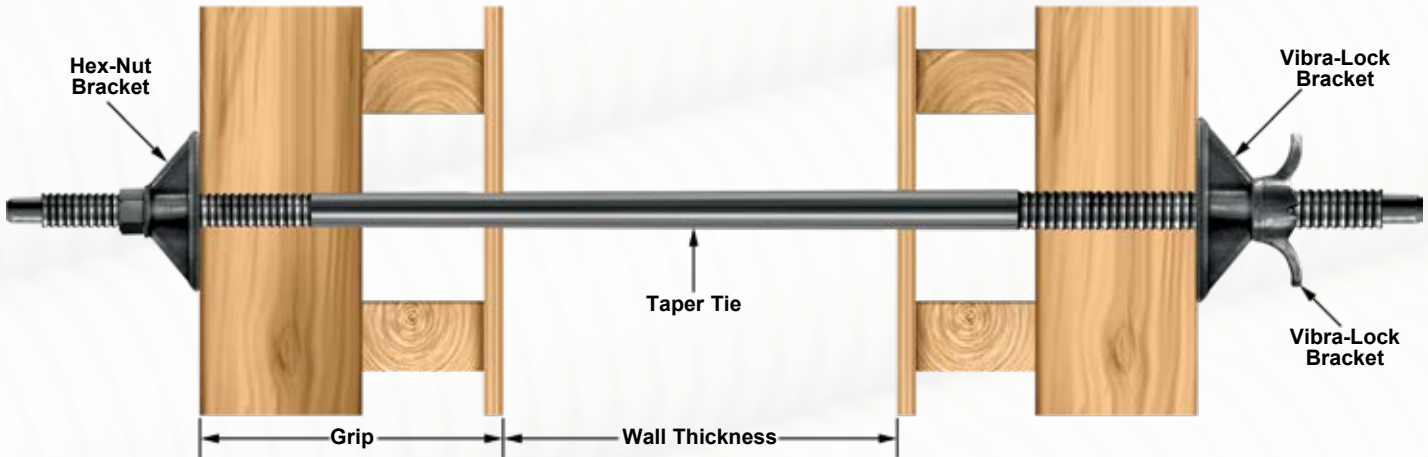

C7T Taper Ties

| Large End Diameter | Small End Diameter | Maximum Taper | Maximum Length | Square Size | Working Load | Ultimate Strength | Wing Nuts | | Vibra-Lock Bracket | | Hex Nut Bracket | |
|--------------------|---------------------|------------------|------------------|-------------------|-----------------------|----------------------|-----------|---------|--------------------|---------|-----------------|-----------------|
| | | | | | | | (A) End | (B) End | (A) End | (B) End | (A) End | (B) End |
| 3/4" (20 mm) | 1/2" (12.7 mm) | 38" (965 mm) | 48" (1219 mm) | 7/16" (11 mm) | 7.5 kips (33.4 kN) | 15 kips (66.7 kN) | W3 | W1 | B3 | B2 | BR10 | Hex Nut & Plate |
| 1" (25 mm) | 3/4" (19.0 mm) | 46" (1168 mm) | 62" (1575 mm) | 5/8" (16 mm) | 18 kips (80.0 kN) | 36 kips (160 kN) | W5T | W5 | B6 | B3 | BR15S | BR10 |
| 1-1/4" (32 mm) | 1" (25.4 mm) | 49" (1245 mm) | 72" (1829 mm) | 13/16" (21 mm) | 34 kips (151 kN) | 68 kips (303 kN) | W6T | W5T | B8 | B6 | BR21 | BR15S |
| 1-1/2" (38 mm) | 1-1/4" (31.8 mm) | 52" (1321 mm) | 84" (2134 mm) | 13/16" (21 mm) | 50 kips (222 kN) | 100 kips (445 kN) | W11 | W6T | Hex Nut & Plate | B8 | Hex Nut & Plate | BR21 |

Step Down Taper Tie System

Williams Step Down Taper Tie System allows the use of the same size external (or outer) hardware such as brackets and wing nuts on both ends of the taper tie. The system consists of totally reusable hardware and is ideal because of its fast assembly and easy strip features. A special dome on each end of the tie is designed to protect the threads from bond breaking hammer blows. All taper ties should be grease coated in their taper section prior to inserting through the form, be checked periodically for wear and cleaned immediately after removal from the form.

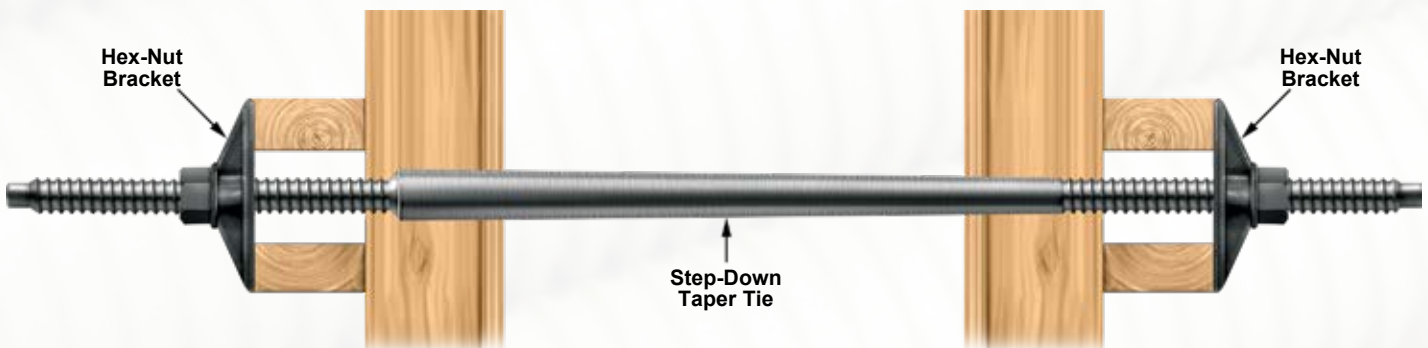



Taper Tie Forming System

Williams Taper Ties offer a steeper taper angle for quicker stripping. Their higher working loads offer faster pour rates. Taper Ties adjust to varying wall thicknesses. All hardware for this system is totally re-usable. The same taper tie may be used to form multiple wall thicknesses as well as battered walls.

Varying Wall Thicknesses

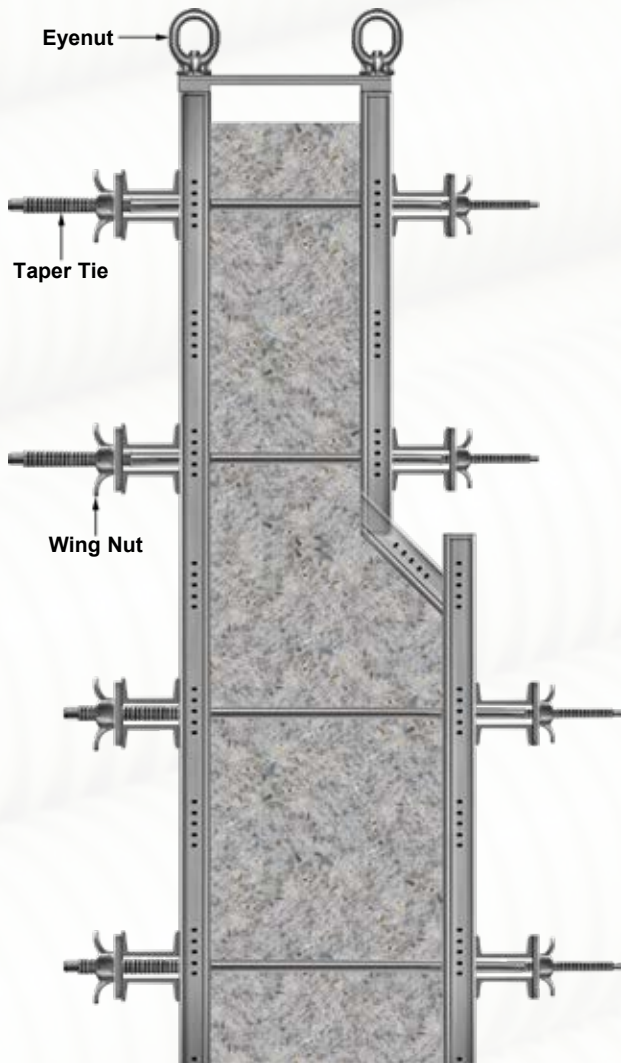

Standard Taper Tie Sizes

| Length (C) | Thread Length | |
|------------------|-----------------|----------------|
| | (A) End | (B) End |
| 30" (762 mm) | 6" (152 mm) | 4" (102 mm) |
| 36" (914 mm) | 8" (203 mm) | 6" (152 mm) |
| 42" (1067 mm) | 8" (203 mm) | 8" (203 mm) |
| 48" (1219 mm) | 8" (203 mm) | 8" (203 mm) |
| 54" (1372 mm) | 8" (203 mm) | 8" (203 mm) |
| 60" (1524 mm) | 10" (254 mm) | 8" (203 mm) |

Please specify when ordering:

- Working Load Requirement
- Diameter
- Length (C)
- Thread Type

Length Calculation:

$$\begin{aligned}
 & \text{Maximum Wall Thickness} && * \text{ (for brackets, removal squares and domed end)} \\
 & + (2 \times \text{Form Grip}) \\
 & + 8 \text{ Inches}^* \\
 \hline
 & = \text{Taper Tie Length (select standard from table)}
 \end{aligned}$$

J4T Thread Chasers

The Thread Chasers were made specially for Williams Threaded products. Designed to clean debris and rust from between the threads while taking out nicks to return the thread back to its original form. Either the handle or the socket holder may be used to hold the thread chaser die.



Thread Chaser Die



J4T Thread Chaser Handle



J4A Die Socket Holder

Thru-Tie System

Williams Through Ties utilizing our standard 3/4" B7S Continuous Thread High Strength Coil Rod, are sheathed with PVC sleeves and reusable plastic spacer cones. This system ensures accurate form spacing and the durable coil thread makes installation and stripping quick and easy. Specify wall widths.

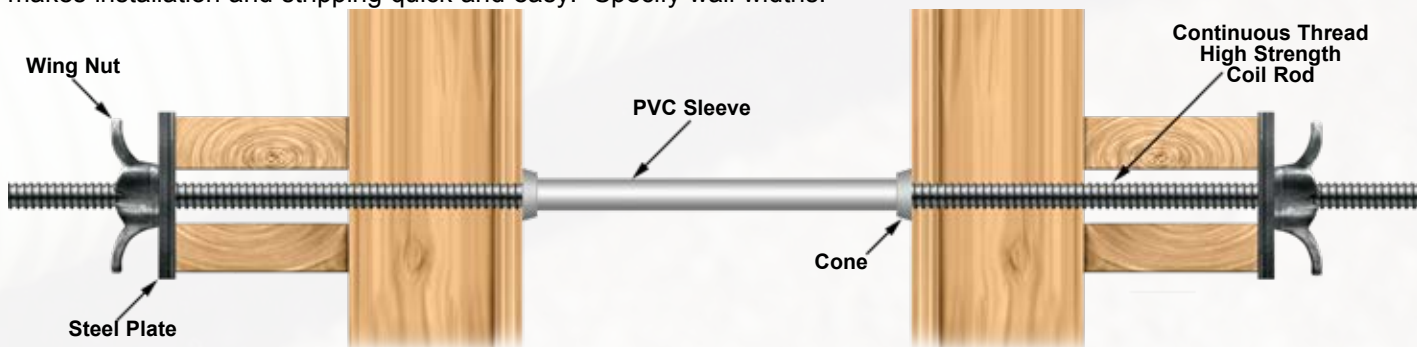



Pigtail / Shebolt System

Williams patented Stress Gradient Pigtail anchor has a unique design, which gradually increases the depth of each crimp to develop a full length Pigtail anchor. The lesser crimps in front allow the Pigtail to elongate through the concrete thereby transferring stress over its entire length. The stress gradient anchor is a positive "non-slip" anchor, which may be placed within 6" of the top of the pour even in low compression strength concrete.

Williams combines the extra strength of stress gradient Pigtail anchors with high tensile steel for more strength per pound than mild steel. A 1/2" high tensile rod will do the work of a 5/8" mild steel rod. Always remember the anchors should be set during pour and no later than one hour after completion of pour. Work concrete well around Pigtail when placing.



B5S Stress Gradient Pigtail Anchor

| Standard Lengths | | Radiused Lengths | | | Safe Working Load (2:1 S.F.) | Ultimate Strength | Shebolt/ Template Bolt Dia. |
|------------------------|---------------|------------------|--------------|----------------|------------------------------|--------------------|-----------------------------|
| Diameter | Total Length | A | B | C Total Length | | | |
| 3/8" - 8 NC (9.5 mm) | 12" (305 mm) | 4" (102 mm) | 10" (254 mm) | 22" (559 mm) | 4.9 kips (21.8 kN) | 9.8 kips (44 kN) | - |
| 1/2" - 13 UNC (13 mm) | 18" (457 mm) | 4" (102 mm) | 10" (254 mm) | 24" (610 mm) | 8.5 kips (38 kN) | 17 kips (76 kN) | 7/8" (22 mm) |
| 5/8" - 11 UNC (16 mm) | 24" (610 mm) | 6" (152 mm) | 12" (305 mm) | 30" (762 mm) | 14 kips (60 kN) | 27 kips (121 kN) | 1" (25 mm) |
| 3/4" - 10 UNC (19 mm) | 24" (610 mm) | 6" (152 mm) | 12" (305 mm) | 30" (762 mm) | 20 kips (89 kN) | 40 kips (178 kN) | 1-1/4" (32 mm) |
| 7/8" - 9 UNC (22 mm) | 30" (762 mm) | 8" (203 mm) | 14" (356 mm) | 36" (914 mm) | 28 kips (123 kN) | 55.4 kips (246 kN) | 1-3/8" (35 mm) |
| 1" - 8 UNC (25 mm) | 36" (914 mm) | 8" (203 mm) | 14" (356 mm) | 42" (1067 mm) | 36 kips (162 kN) | 72.7 kips (323 kN) | 1-1/2" (38 mm) |
| 1-1/8" - 7 UNC (29 mm) | 36" (914 mm) | N.A. | N.A. | N.A. | 41 kips (180 kN) | 81 kips (360 kN) | 1-3/4" (44 mm) |
| 1-1/4" - 7 UNC (32 mm) | 42" (1067 mm) | N.A. | N.A. | N.A. | 51 kips (254 kN) | 102 kips (508 kN) | 2" (51 mm) |
| 2" - 6 UN (51 mm) | 72" (1829 mm) | N.A. | N.A. | N.A. | 139 kips (657 kN) | 279 kips (1313 kN) | - |

Pigtail lengths shown are recommended for 3000 PSI concrete or better. N.A. = Not Available
1-1/8" diameter available in coil thread only.

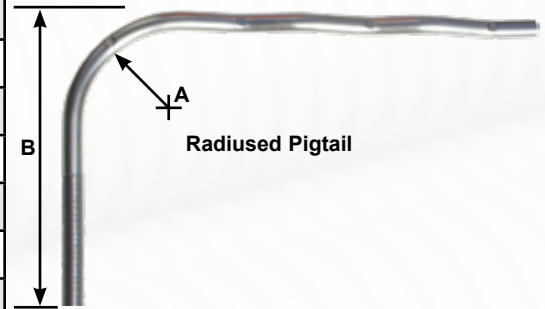

Pigtail / Shebolt System vs. Coil Loop / He-Bolt System



Pigtail / Shebolt System

When re-attaching for subsequent pours, the shebolt nut is tightened until the pigtail anchor is prestressed to the desired load of the next pour. Since the Pigtail diameter is smaller than the shebolt diameter there is no concrete in front of the Pigtail. Therefore the Pigtail can be prestressed without damaging the concrete.



Coil Loop / He-Bolt System

When the he-bolt is re-attached to a coil loop, a section of concrete is trapped between the larger diameter coil loop insert and the outside edge of the concrete. As the he-bolt nut is tightened to prestress the coil loop, this section of concrete is placed under compression prohibiting the anchor from being properly prestressed and creating a probable cause for concrete spalling as the forms are loaded.

He-Bolt



| Large Diameter | Small Diameter | Square End | Safe Working Load | Shear Safe WL |
|----------------|----------------|--------------|-------------------|------------------|
| 1-1/4" (32 mm) | 1" (25 mm) | 3/4" (19 mm) | 34 kips (151 kN) | 23 kips (102 kN) |
| 1-1/2" (38 mm) | 1-1/4" (32 mm) | 1" (25 mm) | 50 kips (222 kN) | 34 kips (151 kN) |

The He Bolt System is fabricated similar to the Shebolt system but has external coil threads at both ends. It is used primarily in conjunction with a previously cast-in-place form anchor to reanchor cantilever forms. He-Bolts are available in two sizes, 1-1/4" x 1" and 1-1/2" x 1-1/4" and are furnished with a square wrench end to aid in the removal process. They will accommodate pour rates up to 10' and are reusable, subject to thread wear. Safe working load is based on an approximate 2:1 safety factor. Note: If setting-pin hole is required, it must be specified when ordering.



Cantilever Forming

Williams cantilever forming system is one of the most efficient and economical systems for forming large concrete structures or re-facements. Williams Pigtail design assures a high load capacity and easy pass through placement from out side of the form.

1st Pour
Use Williams anchors in kicker one side form fit.

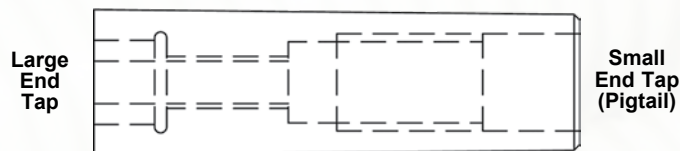
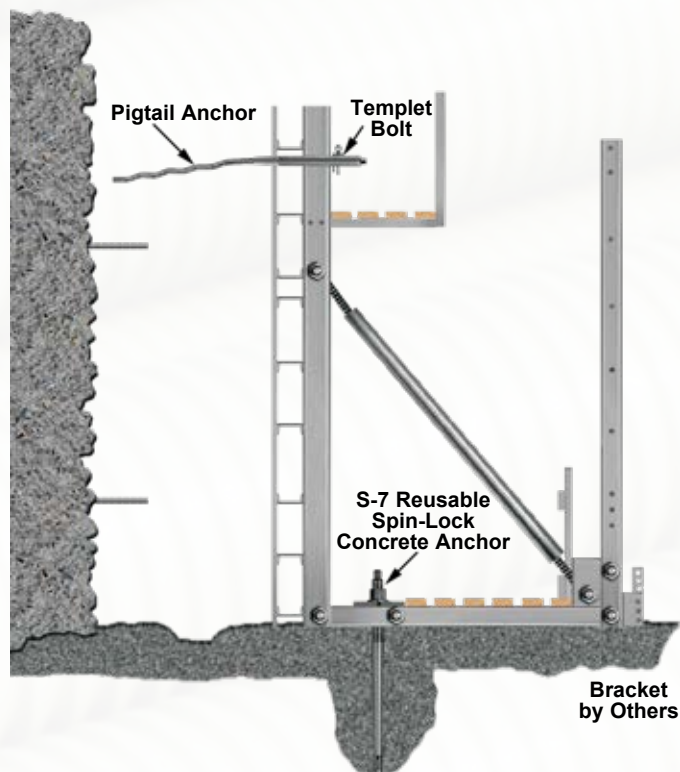

F4T Pigtail Placement Cones

May be used to replace Templet Bolt when placing Pigtails. All cones have a 3/4" hex broach for easy removal. The OD of the cone is similar to the shebolt taper.

| Pigtail Size (Small End Tap) | Bolt Diameter (Large End Tap) | Large Diameter | Small Diameter | Length |
|------------------------------|-------------------------------|----------------|------------------|-----------------|
| 3/4" (19 mm) | 3/8" (9.5 mm) | 1-1/4" (32 mm) | 1-5/32" (29 mm) | 4" (102 mm) |
| 3/4" (19 mm) | 1/2" (13 mm) | 1-1/4" (32 mm) | 1-5/32" (29 mm) | 4" (102 mm) |
| 7/8" (22 mm) | 1/2" (13 mm) | 1-1/2" (38 mm) | 1-13/32" (36 mm) | 6" (152 mm) |
| 7/8" (22 mm) | 1/2" (13 mm) | 1-1/2" (38 mm) | 1-9/16" (40 mm) | 5" (127 mm) |
| 1" (25 mm) | 1/2" (13 mm) | 1-5/8" (41 mm) | 1-9/16" (40 mm) | 5-1/2" (140 mm) |
| 1" (25 mm) | 1/2" (13 mm) | 1-5/8" (41 mm) | 1-9/16" (40 mm) | 6" (152 mm) |

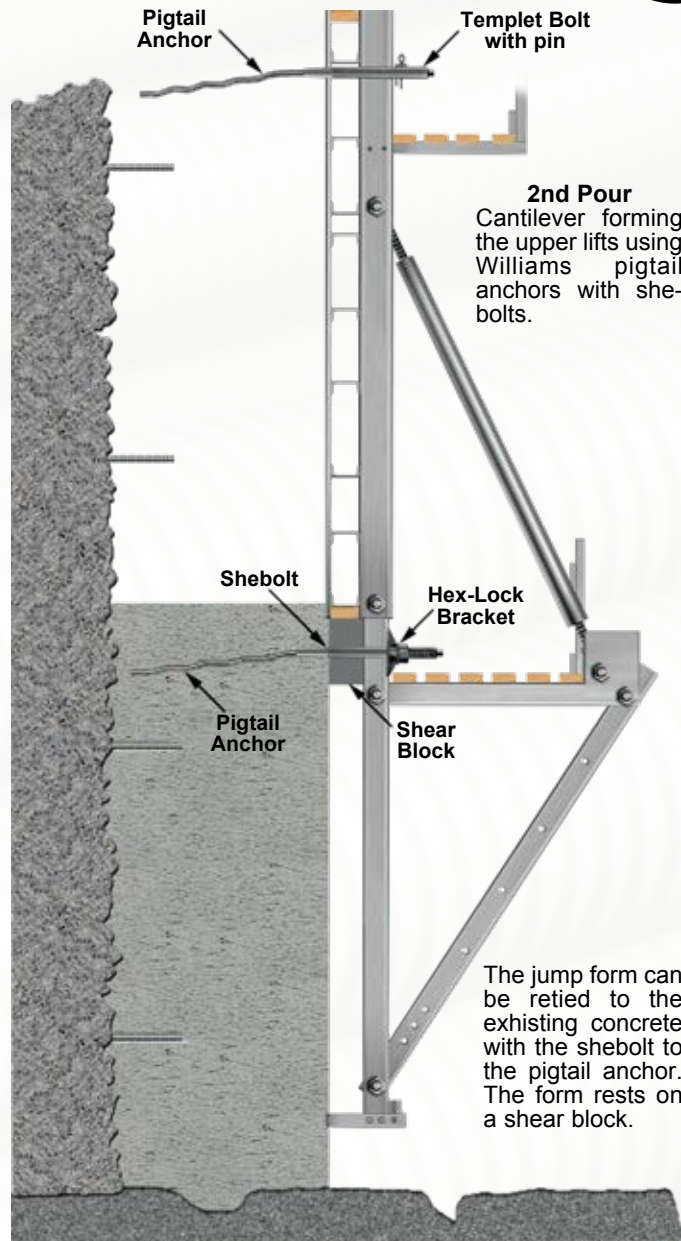

C6T Templet Bolt with C6B Steel Forms Bracket

Williams Templet Bolts offer a convenient and inexpensive method of placing Pigtail anchors in cantilever forming. These bolts have factory-drilled holes to secure quick placement. Templet Bolts are available in the same standard diameters as Williams Shebolts and have matching tapers. Standard lengths from 18" to 30". Other sizes on request.





Forming Off Steel

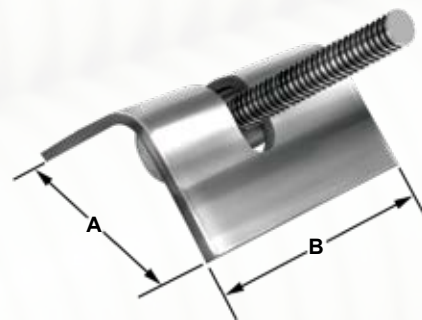
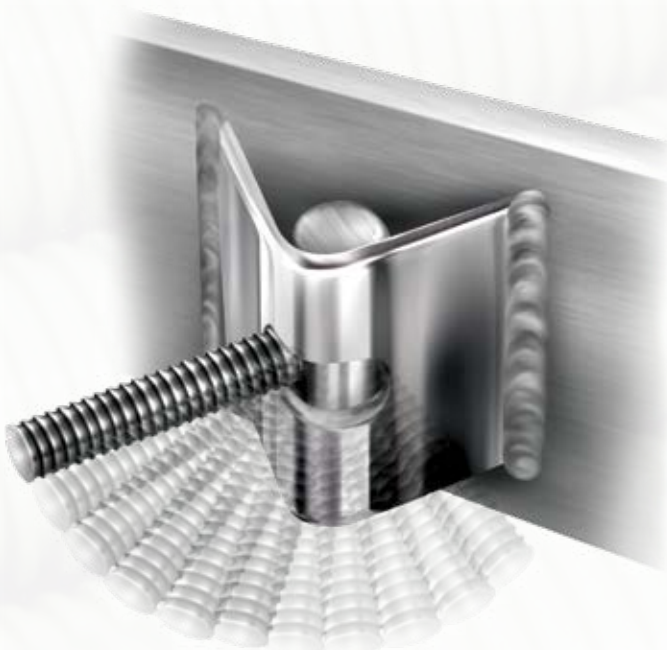
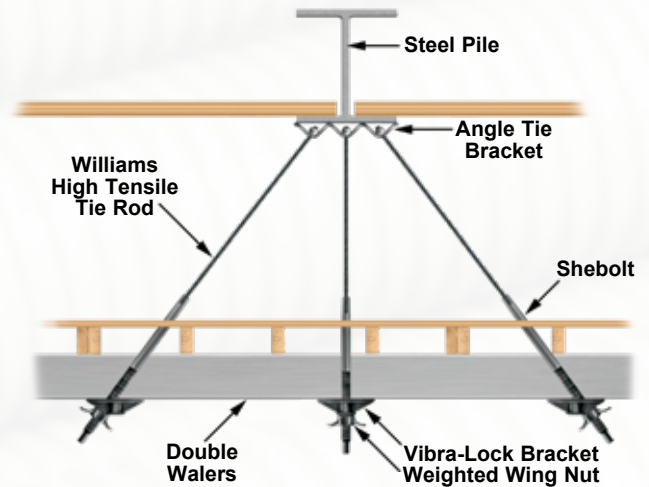
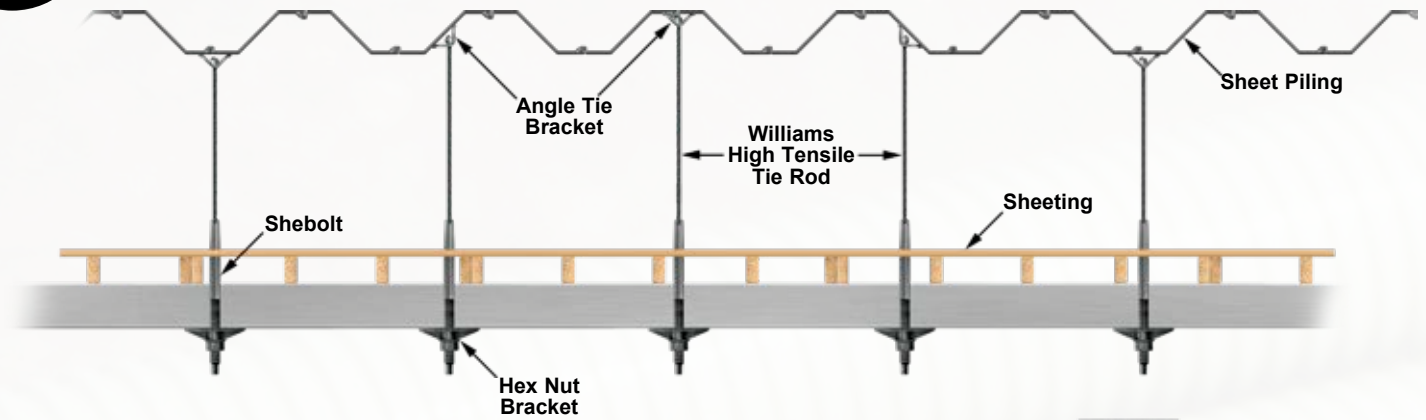

B9D Angle Tie Bracket With Adjustable Tie Rod Angle

Williams Angle Tie Bracket has a full 90° movement with 45° degrees in either direction. It was designed to eliminate the need for unsafe bending of plates and rods in the field. Because the tie rod can be adjusted, the bracket provides an anchor for those angled surfaces such as: sheet piling, I-Beams, or other situations where the tie may not be perpendicular.

The bracket was designed with maximum strength in mind. By simply welding both sides, the bracket is secure and may now be adjusted to any angle required. Available in NC or coil thread. For 1/2", 5/8", 3/4", 7/8" and 1" rod diameters.

The above strengths are based on full fillet welds of individual bracket thicknesses to a cleaned ASTM A36 structural (carbon steel) surface when welded in accordance with A.W.S. standard welding procedures. This product is not intended for use in permanent structure design. Williams Form Engineering Corp. assumes no responsibility nor liability for the welded connection of this product.

| Bar Diameter | Plate Size | | Working Load | Ultimate Strength |
|-----------------|----------------|--------------------|---------------------|---------------------|
| | (A) | (B) | | |
| 1/2" (13 mm) | 5" (125 mm) | 3-1/2" (90 mm) | 9 kips (40 kN) | 18 kips (80 kN) |
| 5/8" (16 mm) | 5" (125 mm) | 4-1/2" (115 mm) | 11 kips (50 kN) | 22 kips (100 kN) |
| 3/4" (19 mm) | 5" (125 mm) | 4-1/2" (115 mm) | 19 kips (85 kN) | 38 kips (169 kN) |
| 7/8" (22 mm) | 5" (125 mm) | 6" (152 mm) | 29 kips (129 kN) | 58 kips (258 kN) |
| 1" (25 mm) | 6" (152 mm) | 6" (152 mm) | 37 kips (167 kN) | 75 kips (334 kN) |



Coil Bolts & Accessories

B10 Coil Bolt

The Coil Bolts are available in 1/2" through 1-1/2" diameters for use with Coil Ties, Coil Inserts and other products furnished with coil threads. Coil Bolts are manufactured with the fast-threading, self-cleaning coil thread and are available in lengths as needed.

Coil Bolts may be furnished with an integral forged head or with a hex nut welded to a length of continuous coil rod. Standard thread length of the integral forged head Coil Bolt is 4" on the 1/2" diameter and 4-1/2" on all other sizes. For minimum coil penetration, see chart below.

Use of waterproof, stain resistant grease applied to the bolt shaft will aid in the bolt removal process. Note that Coil Bolts are subject to wear and misuse and should be continually inspected for wear, cracks, bends, overstressing, etc. If there is any indication of these types of problems, the bolt should be discarded.



| Diameter & Pitch | Minimum Coil Penetration | Safe Working Load (2:1 SF) | | Minimum Net Area Thru Threads |
|---------------------------|--------------------------|----------------------------|---------------------|---|
| | | Tension | Shear | |
| 1/2" - 6 (13 mm) | 2" (51 mm) | 9 kips (40 kN) | 6 kips (27 kN) | 0.14 in ² (89.4 mm ²) |
| 3/4" - 4-1/2 (19 mm) | 2-1/2" (64 mm) | 18 kips (80 kN) | 12 kips (53 kN) | 0.31 in ² (199 mm ²) |
| 1" - 3-1/2 (25 mm) | 2-1/2" (64 mm) | 38 kips (169 kN) | 25 kips (111 kN) | 0.54 in ² (349 mm ²) |
| 1-1/4" 3-1/2 (32 mm) | 3" (76 mm) | 56 kips (249 kN) | 40 kips (178 kN) | 0.92 in ² (591 mm ²) |
| 1-1/2" - 3-1/2 (38 mm) | 3" (76 mm) | 68 kips (302 kN) | 45 kips (200 kN) | 1.39 in ² (896 mm ²) |

B12 Adjustable Coil Bolt

The Adjustable Coil Bolt consists of a length of Coil Rod with a Coil Nut welded on one end and a free running Coil Nut on the threaded section. This unit simplifies ordering on projects where unusual forming conditions require numerous bolt lengths. The Adjustable Coil Bolt is available in 1/2" and 3/4" diameters in standard 18" and 24" lengths. Other diameters and lengths are available on special order.



WARNING: Minimum coil penetration is extremely important and must be adhered to when threading Coil Bolts into other coil-threaded products. Safe working loads are dependent on maintaining the appropriate minimum coil penetration; failure to do so can lead to a premature failure of the coil and compromise worker safety. Refer to the table for safe working loads and minimum coil penetration lengths.

B15 Cone-Fast Cones

The Cone-Fast Cones are designed with internal coil threads to engage the protruding coils of the Cone-Fast Coil Tie and provide a positive form spreader action.

Cone-Fast Cones are stocked in all Cone-Fast Coil Tie diameters. Reference the table for cone dimensions and setback. Safe working load is based on approximate 2:1 safety factor.



| Bolt Diameter | Setback | Overall Length | Width |
|-------------------|-------------------|-------------------|-------------------|
| 1/2" (13 mm) | 1" (25 mm) | 1-3/8" (35 mm) | 1-1/4" (32 mm) |
| 1/2" (13 mm) | 1-1/2" (38 mm) | 1-7/8" (48 mm) | 1-1/4" (32 mm) |
| 1/2" (13 mm) | 2" (51 mm) | 2-3/8" (60 mm) | 1-1/4" (32 mm) |
| 3/4" (19 mm) | 1" (25 mm) | 1-1/2" (38 mm) | 1-3/4" (45 mm) |
| 3/4" (19 mm) | 2" (51 mm) | 2-1/2" (64 mm) | 1-3/4" (45 mm) |
| 3/4" (19 mm) | 3" (76 mm) | 3-1/2" (89 mm) | 1-3/4" (45 mm) |
| 1" (25 mm) | 1" (25 mm) | 1-1/2" (38 mm) | 2-1/8" (54 mm) |
| 1" (25 mm) | 2" (51 mm) | 2-1/2" (64 mm) | 2-1/8" (54 mm) |
| 1" (25 mm) | 3" (76 mm) | 3-1/2" (89 mm) | 2-1/8" (54 mm) |
| 1-1/4" (32 mm) | 1" (25 mm) | 1-1/2" (38 mm) | 2-3/8" (60 mm) |
| 1-1/4" (32 mm) | 2" (51 mm) | 2-1/2" (64 mm) | 2-3/8" (60 mm) |

Coil Tie Water Seal

All Two Strut and Four Strut Coil Ties are available with a neoprene rubber washer installed on each wire strut. The neoprene washers help prevent the seepage of water along the wire struts. In damp or wet conditions this is a beneficial addition to the form tie system.



B16 Cone Wrench

The Cone Wrench is available in sizes corresponding to the Cone-Fast Cones (above) to facilitate the removal of the cones from the concrete.

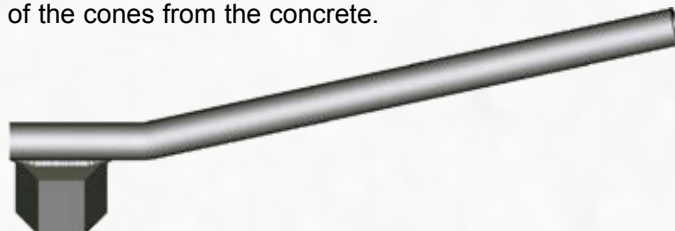



Coil Ties

C12 Two Strut Coil Tie

The Two Strut Coil Tie is fabricated with two struts and two self-cleaning, fast threading coils and is available in a broad range of sizes and safe working loads. The versatile tie is used with Coil Bolts or Coil Rod to handle the many forming variations encountered. The Two Strut Coil Tie is available in 1/2" to 1" diameters in standard and heavy types. Safe working load is based on an approximate 2:1 safety factor. Note: If electron-plating of coil ties is required, special procedures may be necessary to prevent hydrogen embrittlement effects. Specify when placing order.

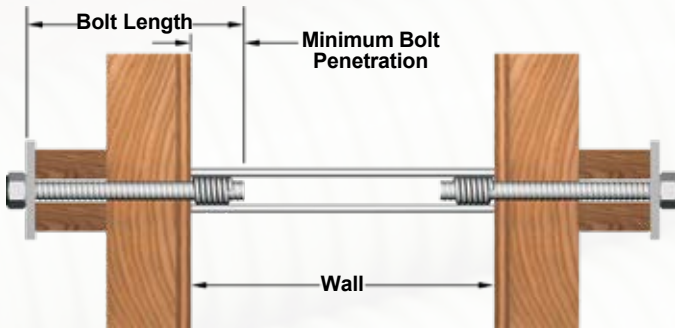

| Diameter | Type | Safe Working Load (Tension) | Approximate Ultimate |
|--------------|----------|-----------------------------|----------------------|
| 1/2" (13 mm) | Standard | 4.5 kips (20 kN) | 9 kips (40 kN) |
| 1/2" (13 mm) | Heavy | 6.75 kips (30 kN) | 13.5 kips (60 kN) |
| 3/4" (19 mm) | Standard | 6.75 kips (30 kN) | 13.5 kips (60 kN) |
| 3/4" (19 mm) | Heavy | 9.0 kips (40 kN) | 18 kips (80 kN) |
| 1" (25 mm) | Standard | 13.5 kips (60 kN) | 27 kips (120 kN) |

See Notes at bottom.

C14 Four Strut Coil Tie

The Four Strut Coil Tie is similar in form and use to the Two Strut Coil Tie, but has two additional struts to develop higher load capacities. Four Strut Coil Ties are available in 1" diameter standard, 1-1/4" standard and heavy configurations. Safe working load is based on an approximate 2:1 safety factor. Note: If electron-plating of coil ties is required, special procedures may be necessary to prevent hydrogen embrittlement effects. Specify when placing order.

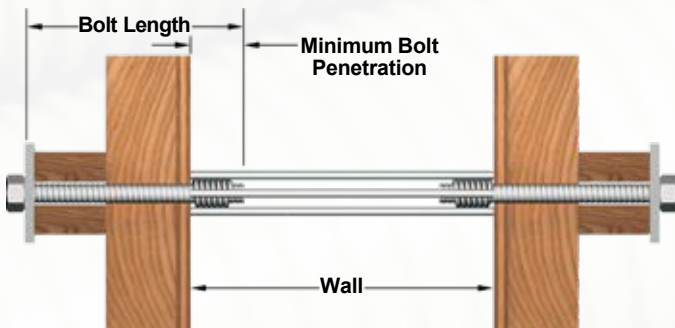
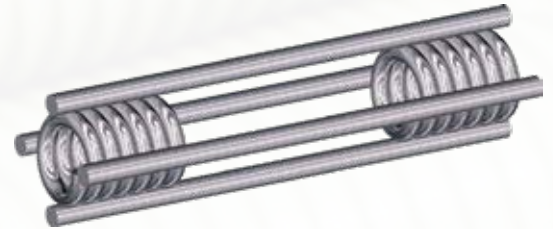

| Diameter | Type | Safe Working Load (Tension) | Approximate Ultimate |
|----------------|----------|-----------------------------|----------------------|
| 1/2" (13 mm) | Heavy | 13.5 kips (60 kN) | 27 kips (120 kN) |
| 3/4" (19 mm) | Heavy | 18 kips (80 kN) | 36 kips (160 kN) |
| 1" (25 mm) | Heavy | 27 kips (120 kN) | 54 kips (240 kips) |
| 1-1/4" (32 mm) | Standard | 27 kips (120 kN) | 54 kips (240 kips) |
| 1-1/4" (32 mm) | Heavy | 30 kips (133 kN) | 60 kips (267 kN) |

CAUTION: When pouring walls over 8' high, consider using the next higher load rated coil tie for additional safety factor. Form pressures tend to be greater than expected or planned when pouring higher walls.

Notes for all Ties and Inserts

- Numbers shown are based on minimum concrete strength of 3,000 PSI.
- Safe working loads are based on 2:1 safety factor for forming and 4:1 safety factor for tension and shear.
- Inserts must have a 1/2" setback from the surface of the concrete and sufficient coil penetration by the lifting bolt.
- Minimum concrete thickness = L + setback + 3/4" clear cover.
- Minimum edge distance apply to 2 edges only. All other edges require 2x length of insert.
- Minimum corner distance shall be 1.5x minimum edge distance for shear when loaded towards the edge.
- Minimum anchor spacing shall be 2x the edge distance for forming and tension and 3x the edge distance for shear.
- Anchors with asterisks exceed the shear capacity of the coil rod.
- Coil Inserts & Ties are available in plain, hot dip galvanize, or stainless steel finish.
- See Page 21 for optional Coil Tie accessories.

WARNING: Minimum coil penetration is extremely important and must be adhered to when threading Coil Bolts into other coil-threaded products. Safe working loads are dependent on maintaining the appropriate minimum coil penetration; failure to do so can lead to a premature failure of the coil and compromise worker safety. Refer to the tables for safe working loads and minimum coil penetration lengths.



Coil Ties

Cone-Fast Coil Ties

The Cone-Fast Coil Ties are fabricated with longer coils that extend beyond the ends of the struts to allow threaded plastic cones to be attached to the Coil Tie. The cones provide a spreader function for the tie as well as a specific setback. They also act as a centering guide when attaching the coil bolts during setup.

Cone-Fast Coil Tie recesses left by the plastic cones provide an architectural effect on the face of the concrete and the setback places the tie back away from the concrete surface to reduce surface corrosion staining.

Cone-Fast Two Strut Coil Ties are available in 1/2", 3/4" and 1" standard and heavy types. The Cone-Fast Four Strut Coil Tie version is available in 1" and 1-1/2" standard and 1-1/4" heavy. Safe working loads of the Cone-Fast Coil Ties are the same as the comparable Two & Four Strut Coil Ties. To determine length, subtract two times the setback from the wall thickness.

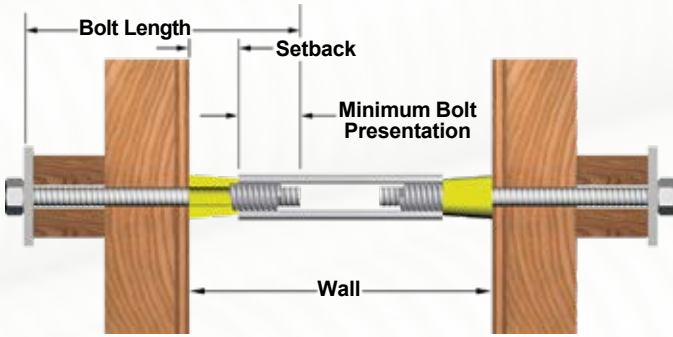

| Bolt Diameter | Setback | Length | Diameter |
|-----------------|-------------------|-------------------|--------------------|
| 1/2" (13 mm) | 1" (25 mm) | 1-3/8" (35 mm) | 1-1/4" (32 mm) |
| 1/2" (13 mm) | 1-1/2" (38 mm) | 1-7/8" (48 mm) | 1-1/4" (32 mm) |
| 1/2" (13 mm) | 2" (51 mm) | 2-3/8" (60 mm) | 1-1/4" (32 mm) |
| 3/4" (19 mm) | 1" (25 mm) | 2-1/2" (64 mm) | 1-3/4" (44 mm) |
| 3/4" (19 mm) | 2" (51 mm) | 2-1/2" (64 mm) | 1-3/4" (44 mm) |
| 1" (25 mm) | 2" (51 mm) | 2-1/2" (64 mm) | 2-1/8" (54 mm) |
| 1" (25 mm) | 2" (51 mm) | 2-1/2" (64 mm) | 2-3/8" (630 mm) |

See Notes on page 22.

C10 Welding Coil Tie

The versatile and economical Two Strut Coil Tie is available with one end open to allow the struts to be field welded when unusual forming situations are encountered. The Welding Coil Tie is available in 1/2", 3/4", and 1" diameters and in overall lengths as required. Actual safe working load is dependent on the quality of the field weld. Safe working load is based on an approximate 2:1 safety factor.

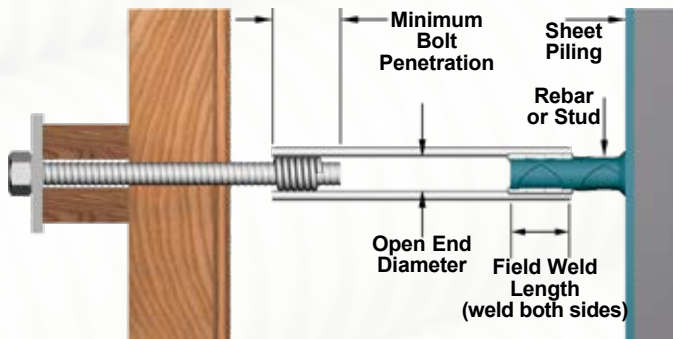

| Bolt Diameter | Wire Diameter | Open End Diameter | Field Weld Length (min) | Safe Working Load |
|-----------------|---------------------|-------------------|-------------------------|---------------------|
| 1/2" (13 mm) | 0.306" (7.77 mm) | 3/4" (19 mm) | 1" (25 mm) | 6.8 kips (30 kN) |
| 3/4" (19 mm) | 0.375" (9.5 mm) | 1" (25 mm) | 1-1/2" (38 mm) | 9 kips (40 kN) |
| 1" (25 mm) | 0.440" (11 mm) | 1-3/8" (35 mm) | 2" (51 mm) | 15 kips (67 kN) |

See Notes on page 22.

C22 Open Coil Insert

The Open Coil Inserts are manufactured with a standard coil connected to an expanded coil by resistance-weld struts. They are available in 3/4" through 1-1/2" bolt diameters with two to six struts, depending on the model. Refer to the table for sizes, dimensions and safe working loads. The Open Coil Insert is also available with a mounting washer for applications requiring the insert to be nailed to the form. Numbers shown are based a 2:1 safety factor.

| Bolt Diameter | Wire Diameter (D) | Overall Length (L) | Coil Width (B) | Coil Length (C) | Open Width (W) | Safe Working Loads | | | Edge Distance | |
|-------------------|--------------------|--------------------|-------------------|-------------------|-------------------|---------------------|---------------------|---------------------|-----------------|-----------------|
| | | | | | | Forming (2:1 SF) | Tension (4:1 SF) | Shear (4:1 SF) | Tension | Shear |
| 3/4" (19 mm) | 0.375" (9.5 mm) | 5" (127 mm) | 1-3/4" (45 mm) | 1-5/8" (41 mm) | 2-1/8" (54 mm) | 8.5 kips (38 kN) | 4.3 kips (19 kN) | 4.3 kips (19 kN) | 7" (178 mm) | 12" (305 mm) |
| 1" (25 mm) | 0.440" (11 mm) | 6" (152 mm) | 2-1/4" (57 mm) | 2-1/8" (54 mm) | 2-1/2" (64 mm) | 13 kips (56 kN) | 6.3 kips (28 kN) | 6.3 kips (28 kN) | 9" (229 mm) | 16" (406 mm) |
| 1" (25 mm) | 0.440" (11 mm) | 8" (203 mm) | 2-1/4" (57 mm) | 2-1/8" (54 mm) | 2-3/4" (70 mm) | 20 kips (89 kN) | 10 kips (44 kN) | 10 kips (44 kN) | 12" (305 mm) | 24" (610 mm) |
| 1-1/4" (32 mm) | 0.440" (11 mm) | 8" (203 mm) | 2-1/2" (64 mm) | 2-1/8" (54 mm) | 3" (76 mm) | 24 kips (107 kN) | 12 kips (53 kN) | 12 kips (53 kN) | 12" (305 mm) | 24" (610 mm) |
| 1-1/4" (32 mm) | 0.440" (11 mm) | 10" (254 mm) | 2-1/2" (64 mm) | 2-1/8" (54 mm) | 3" (76 mm) | 32 kips (142 kN) | 16 kips (71 kN) | 16 kips (71 kN) | 16" (406 mm) | 26" (660 mm) |
| 1-1/2" (38 mm) | 0.440" (11 mm) | 10" (254 mm) | 2-3/4" (70 mm) | 2-1/8" (54 mm) | 3" (76 mm) | 32 kips (142 kN) | 16 kips (71 kN) | 16 kips (71 kN) | 16" (406 mm) | 26" (660 mm) |

See Notes on page 22.

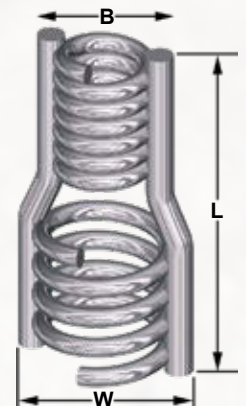



Coil Loop Inserts

C15 Straight Coil Loop Insert

The Straight Coil Loop Insert is fabricated with one straight loop strut resistance welded to a coil. They are available in the standard lengths shown, other lengths and equipped with Cone-Fast Cones are available on special order. Although it is not recommended for use as a lifting insert, this anchor is widely used in the precast industry for bolted connections. It is available in plain, hot dip galvanize finish, or stainless steel finish.

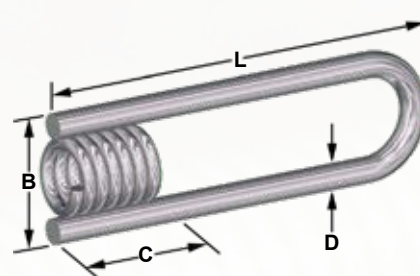

| Bolt Diameter | Wire Diameter (D) | Overall Length (L) | Width (B) | Coil Length (C) | Safe Working Loads | | | Edge Distance | |
|----------------|-------------------|--------------------|------------------|-----------------|--------------------|------------------|-------------------|---------------|--------------|
| | | | | | Forming (2:1 SF) | Tension (4:1 SF) | Shear (4:1 SF) | Tension | Shear |
| 1/2" (13 mm) | 0.225" (5.7 mm) | 4" (102 mm) | 1-3/16" (30 mm) | 1-3/16" (30 mm) | 4.5 kips (20 kN) | 2.3 kips (10 kN) | 2.0 kips (8.9 kN) | 7" (178 mm) | 9" (229 mm) |
| 1/2" (13 mm) | 0.306" (7.77 mm) | 6" (152 mm) | 1-3/8" (35 mm) | 1-3/16" (30 mm) | 7.2 kips (32.0 kN) | 3.6 kips (16 kN) | 3.0 kips (13 kN) | 10" (254 mm) | 10" (254 mm) |
| 3/4" (19 mm) | 0.306" (7.77 mm) | 4" (102 mm) | 1-11/16" (43 mm) | 1-5/8" (41 mm) | 6.2 kips (28 kN) | 3.1 kips (14 kN) | 2.8 kips (13 kN) | 7" (178 mm) | 10" (254 mm) |
| 3/4" (19 mm) | 0.375" (9.5 mm) | 6" (152 mm) | 1-7/8" (48 mm) | 1-5/8" (41 mm) | 9.0 kips (40 kN) | 4.5 kips (20 kN) | 4.2 kips (19 kN) | 10" (254 mm) | 12" (305 mm) |
| 1" (25 mm) | 0.375" (9.5 mm) | 6" (152 mm) | 2-1/8" (54 mm) | 2-1/8" (54 mm) | 9.0 kips (40 kN) | 4.5 kips (20 kN) | 4.2 kips (20 kN) | 10" (254 mm) | 12" (305 mm) |
| 1" (25 mm) | 0.375" (9.5 mm) | 8" (203 mm) | 2-1/8" (54 mm) | 2-1/8" (54 mm) | 9.0 kips (40 kN) | 4.5 kips (20 kN) | 4.2 kips (20 kN) | 13" (330 mm) | 13" (330 mm) |
| 1-1/4" (32 mm) | 0.440" (11 mm) | 8" (203 mm) | 2-1/2" (64 mm) | 2-1/16" (52 mm) | 12 kips (53 kN) | 6 kips (27 kN) | 5.8 kips (26 kN) | 13" (330 mm) | 13" (330 mm) |

See Notes at bottom.

C16 Criss-Cross Straight Loop Insert

The Straight Criss Cross Coil Loop Insert is constructed very much like the flared version but has two straight loops and is well suited for thin wall applications. This is a high strength four strut insert ideally suited for precast concrete edge lift applications. The four strut design and high safe working loads make this insert a good, safe choice for preventing panel failures.

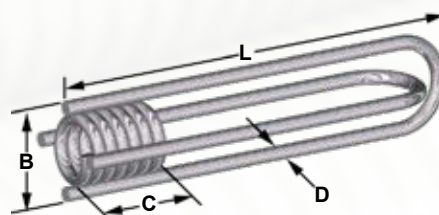

| Bolt Diameter | Wire Diameter (D) | Overall Length (L) | Width (B) | Coil Length (C) | Safe Working Loads | | | Edge Distance | |
|----------------|-------------------|--------------------|------------------|-----------------|--------------------|------------------|------------------|---------------|--------------|
| | | | | | Forming (2:1 SF) | Tension (4:1 SF) | Shear (4:1 SF) | Tension | Shear |
| 3/4" (19 mm) | 0.306" (7.77 mm) | 9" (229 mm) | 1-11/16" (43 mm) | 1-5/8" (41 mm) | 14 kips (60 kN) | 6.8 kips (30 kN) | 6.8 kips (30 kN) | 12" (305 mm) | 16" (406 mm) |
| 3/4" (19 mm) | 0.306" (7.77 mm) | 12" (305 mm) | 1-11/16" (43 mm) | 1-5/8" (41 mm) | 14 kips (60 kN) | 6.8 kips (30 kN) | 6.8 kips (30 kN) | 12" (305 mm) | 16" (406 mm) |
| 1" (25 mm) | 0.306" (7.77 mm) | 9" (229 mm) | 2-1/8" (54 mm) | 2-1/8" (54 mm) | 14 kips (60 kN) | 6.8 kips (30 kN) | 6.8 kips (30 kN) | 12" (305 mm) | 16" (406 mm) |
| 1" (25 mm) | 0.306" (7.77 mm) | 12" (305 mm) | 2-1/8" (54 mm) | 2-1/8" (54 mm) | 14 kips (60 kN) | 6.8 kips (30 kN) | 6.8 kips (30 kN) | 12" (305 mm) | 16" (406 mm) |
| 1" (25 mm) | 0.375" (9.5 mm) | 9" (229 mm) | 2-1/8" (54 mm) | 2-1/8" (54 mm) | 18 kips (80 kN) | 9 kips (40 kN) | 7.9 kips (35 kN) | 16" (406 mm) | 16" (406 mm) |
| 1" (25 mm) | 0.375" (9.5 mm) | 12" (305 mm) | 2-1/8" (54 mm) | 2-1/8" (54 mm) | 18 kips (80 kN) | 9 kips (40 kN) | 9 kips (40 kN) | 16" (406 mm) | 16" (406 mm) |
| 1-1/4" (32 mm) | 0.440" (11 mm) | 9" (229 mm) | 2-1/2" (64 mm) | 2-1/8" (54 mm) | 27 kips (120 kN) | 14 kips (60 kN) | 9.6 kips (43 kN) | 16" (406 mm) | 20" (508 mm) |
| 1-1/4" (32 mm) | 0.440" (11 mm) | 12" (305 mm) | 2-1/2" (64 mm) | 2-1/8" (54 mm) | 27 kips (120 kN) | 14 kips (60 kN) | 14 kips (55 kN) | 20" (508 mm) | 20" (508 mm) |

Notes for all Ties and Inserts

1. Numbers shown are based on minimum concrete strength of 3,000 PSI.
2. Safe working loads are based on 2:1 safety factor for forming and 4:1 safety factor for tension and shear.
3. Inserts must have a 1/2" setback from the surface of the concrete and sufficient coil penetration by the lifting bolt.
4. Minimum concrete thickness = L + setback + 3/4" clear cover.
5. Minimum edge distance apply to 2 edges only. All other edges require 2x length of insert.
6. Minimum corner distance shall be 1.5x minimum edge distance for shear when loaded towards the edge.
7. Minimum anchor spacing shall be 2x the edge distance for forming and tension and 3x the edge distance for shear.
8. Anchors with asterisks exceed the shear capacity of the coil rod.
9. Coil Inserts & Ties are available in plain, hot dip galvanize, or stainless steel finish.
10. See Page 21 for optional Coil Tie accessories.

WARNING: Minimum coil penetration is extremely important and must be adhered to when threading Coil Bolts into other coil-threaded products. Safe working loads are dependent on maintaining the appropriate minimum coil penetration; failure to do so can lead to a premature failure of the coil and compromise worker safety. Refer to the tables for safe working loads and minimum coil penetration lengths.



Coil Loop Inserts

C19 Flared Coil Loop Insert

The Flared Coil Loop Insert is manufactured with a flared loop strut resistance welded to a coil for increased tensile capacity. This being a two-strut insert, it is not recommended for lifting purposes. It does find numerous applications as a structural connection and other bolted connection applications.

Warning: This insert is not efficient as an edge lifting insert and is not recommended as such. This insert will usually fail when low strength concrete spalls on top of the insert and will generally result in loss of the panel.

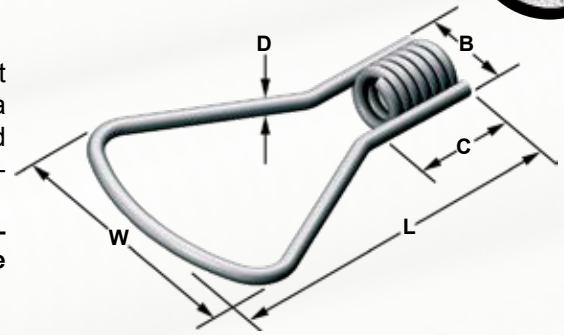

| Bolt Diameter | Wire Diameter (D) | Overall Length (L) | Width (B) | Coil Length (C) | Flare Width (W) | Safe Working Loads | | | Edge Distance | |
|----------------|-------------------|--------------------|----------------|-----------------|-----------------|--------------------|------------------|------------------|---------------|--------------|
| | | | | | | Forming (2:1 SF) | Tension (4:1 SF) | Shear (4:1 SF) | Tension | Shear |
| 3/4" (19 mm) | 0.375" (9.5 mm) | 6" (152 mm) | 1-3/4" (45 mm) | 1-3/4" (45 mm) | 3-1/2" (89 mm) | 9.0 kips (40 kN) | 4.8 kips (21 kN) | 4.3 kips (19 kN) | 13" (330 mm) | 13" (330 mm) |
| 3/4" (19 mm) | 0.375" (9.5 mm) | 9" (229 mm) | 1-3/4" (45 mm) | 1-3/4" (45 mm) | 5-1/2" (140 mm) | 9.0 kips (40 kN) | 4.8 kips (21 kN) | 4.8 kips (21 kN) | 13" (330 mm) | 13" (330 mm) |
| 1" (25 mm) | 0.375" (9.5 mm) | 9" (229 mm) | 2-1/8" (54 mm) | 2-1/16" (52 mm) | 5-1/2" (140 mm) | 9.0 kips (40 kN) | 4.8 kips (21 kN) | 4.8 kips (21 kN) | 15" (381 mm) | 15" (381 mm) |
| 1" (25 mm) | 0.440" (11 mm) | 9" (229 mm) | 2-1/2" (64 mm) | 2-1/16" (52 mm) | 5-3/4" (146 mm) | 14 kips (60 kN) | 8.0 kips (36 kN) | 7.3 kips (32 kN) | 15" (381 mm) | 16" (406 mm) |
| 1" (25 mm) | 0.375" (9.5 mm) | 12" (305 mm) | 2-1/8" (54 mm) | 2-1/16" (52 mm) | 5-1/2" (140 mm) | 9.0 kips (40 kN) | 4.8 kips (21 kN) | 4.8 kips (21 kN) | 15" (381 mm) | 15" (381 mm) |
| 1" (25 mm) | 0.440" (11 mm) | 12" (305 mm) | 2-1/2" (64 mm) | 2-1/16" (52 mm) | 5-3/4" (146 mm) | 14 kips (60 kN) | 8.0 kips (36 kN) | 7.3 kips (32 kN) | 15" (381 mm) | 16" (406 mm) |
| 1-1/4" (32 mm) | 0.375" (9.5 mm) | 12" (305 mm) | 2-1/2" (64 mm) | 2-5/16" (59 mm) | 5-3/4" (146 mm) | 9.0 kips (40 kN) | 4.8 kips (21 kN) | 4.8 kips (21 kN) | 15" (381 mm) | 15" (381 mm) |
| 1-1/4" (32 mm) | 0.440" (11 mm) | 12" (305 mm) | 2-1/2" (64 mm) | 2-5/16" (59 mm) | 5-3/4" (146 mm) | 15 kips (67 kN) | 8.0 kips (36 kN) | 7.3 kips (32 kN) | 15" (381 mm) | 16" (406 mm) |
| 1-1/2" (38 mm) | 0.440" (11 mm) | 12" (305 mm) | 2-3/4" (70 mm) | 2-9/16" (65 mm) | 5-3/4" (146 mm) | 15 kips (67 kN) | 8.0 kips (36 kN) | 7.3 kips (32 kN) | 15" (381 mm) | 16" (406 mm) |

See Notes on page 24.

C20 Double Flared Coil Loop Insert

The Double Flared Coil Loop Insert has two flared loop struts resistance welded to the coil. It is a four-strut insert available in two styles: the standard flared struts version and the parallel struts version for more confined applications where space is lacking. The four-strut insert offers increased shear and tension capacities and is used effectively in many precast concrete lifting and handling applications. This insert is well suited for low strength concrete applications and can easily accommodate 5' to 7-1/2' lifts.

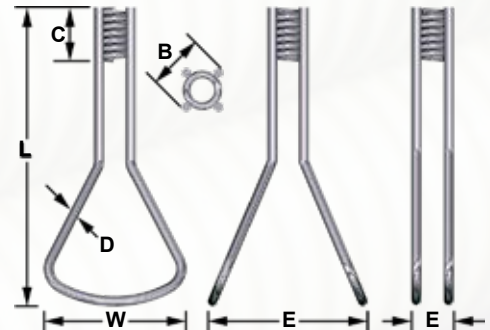

| Bolt Dia. | Wire Diameter (D) | Overall Length (L) | Width (B) | Coil Length (C) | Flare Width (W) | Flare Dist. (E) | Safe Working Loads | | | Edge Distance | |
|----------------|-------------------|--------------------|-----------------|-----------------|-----------------|-----------------|--------------------|------------------|------------------|---------------|--------------|
| | | | | | | | Forming (2:1 SF) | Tension (4:1 SF) | Shear (4:1 SF) | Tension | Shear |
| 1" (25 mm) | 0.375" (9.5 mm) | 12" (305 mm) | 2-1/8" (54 mm) | 2-1/8" (54 mm) | 5-1/2" (140 mm) | 1-1/4" (32 mm) | 18 kips (80 kN) | 9.5 kips (42 kN) | 9.5 kips (42 kN) | 15" (381 mm) | 18" (457 mm) |
| 1" (25 mm) | 0.440" (11 mm) | 12" (305 mm) | 2-1/4" (57 mm) | 2-1/8" (54 mm) | 5-3/4" (146 mm) | 1-1/4" (32 mm) | 27 kips (120 kN) | 14 kips (60 kN) | 14 kips (60 kN) | 20" (508 mm) | 24" (610 mm) |
| 1-1/4" (32 mm) | 0.375" (9.5 mm) | 12" (305 mm) | 2-5/16" (59 mm) | 2-1/16" (52 mm) | 5-3/4" (146 mm) | 1-1/2" (38 mm) | 18 kips (80 kN) | 9.5 kips (42 kN) | 9.5 kips (42 kN) | 15" (381 mm) | 18" (457 mm) |
| 1-1/4" (32 mm) | 0.440" (11 mm) | 12" (305 mm) | 2-1/2" (64 mm) | 2-1/16" (52 mm) | 5-3/4" (146 mm) | 1-1/2" (38 mm) | 32 kips (142 kN) | 14 kips (60 kN) | 14 kips (60 kN) | 20" (508 mm) | 24" (610 mm) |
| 1" (25 mm) | 0.375" (9.5 mm) | 12" (305 mm) | 2-1/16" (52 mm) | 2-1/8" (54 mm) | 5-1/2" (140 mm) | 5-1/2" (140 mm) | 18 kips (80 kN) | 9.5 kips (42 kN) | 9.5 kips (42 kN) | 15" (381 mm) | 18" (457 mm) |
| 1" (25 mm) | 0.440" (11 mm) | 12" (305 mm) | 2-1/4" (57 mm) | 2-1/8" (54 mm) | 5-3/4" (146 mm) | 5-3/4" (146 mm) | 27 kips (120 kN) | 14 kips (60 kN) | 14 kips (60 kN) | 20" (508 mm) | 24" (610 mm) |
| 1-1/4" (32 mm) | 0.375" (9.5 mm) | 12" (305 mm) | 2-5/16" (59 mm) | 2-1/8" (54 mm) | 5-3/4" (146 mm) | 5-3/4" (146 mm) | 18 kips (80 kN) | 9.5 kips (42 kN) | 9.5 kips (42 kN) | 15" (381 mm) | 18" (457 mm) |
| 1-1/4" (32 mm) | 0.440" (11 mm) | 12" (305 mm) | 2-1/2" (64 mm) | 2-1/8" (54 mm) | 5-3/4" (146 mm) | 5-3/4" (146 mm) | 32 kips (142 kN) | 14 kips (60 kN) | 14 kips (60 kN) | 20" (508 mm) | 24" (610 mm) |
| 1-1/2" (38 mm) | 0.375" (9.5 mm) | 12" (305 mm) | 2-9/16" (65 mm) | 2-1/8" (54 mm) | 5-3/4" (146 mm) | 5-3/4" (146 mm) | 18 kips (80 kN) | 9.5 kips (42 kN) | 9.5 kips (42 kN) | 15" (381 mm) | 18" (457 mm) |
| 1-1/2" (38 mm) | 0.440" (11 mm) | 12" (305 mm) | 2-3/4" (70 mm) | 2-1/8" (54 mm) | 5-3/4" (146 mm) | 5-3/4" (146 mm) | 32 kips (142 kN) | 14 kips (60 kN) | 14 kips (60 kN) | 20" (508 mm) | 24" (610 mm) |

See Notes on page 24.



Coil Inserts

C21 Criss Cross Flared Coil Loop Insert

The Criss Cross Flared Coil Loop Insert is similar to the double flared insert but has the strut wires welded in a crossing pattern. It is available in 1", 1-1/4" and 1-1/2" diameters and in the lengths and safe working loads shown in the table. This insert is applicable for 5' to 7-1/2' lifts.

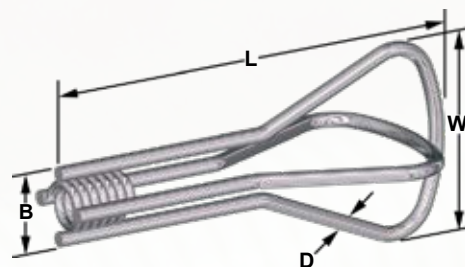

| Bolt Diameter | Wire Diameter (D) | Overall Length (L) | Width (B) | Coil Length (C) | Flare Width (W) | Flare Dist. (E) | Safe Working Loads | | | Edge Distance | |
|----------------|-------------------|--------------------|-----------------|-----------------|-----------------|-----------------|--------------------|------------------|------------------|---------------|--------------|
| | | | | | | | Forming (2:1 SF) | Tension (4:1 SF) | Shear (4:1 SF) | Tension | Shear |
| 1" (25 mm) | 0.375" (9.5 mm) | 12-3/8" (314 mm) | 2-1/16" (52 mm) | 2-1/8" (54 mm) | 5-1/2" (140 mm) | 5-1/2" (140 mm) | 19 kips (85 kN) | 9.5 kips (42 kN) | 9.5 kips (42 kN) | 15" (381 mm) | 18" (457 mm) |
| 1" (25 mm) | 0.440" (11 mm) | 12-1/2" (318 mm) | 2-1/4" (57 mm) | 2-1/8" (54 mm) | 5-3/4" (146 mm) | 5-3/4" (146 mm) | 27 kips (120 kN) | 14 kips (60 kN) | 14 kips (60 kN) | 20" (508 mm) | 24" (610 mm) |
| 1-1/4" (32 mm) | 0.375" (9.5 mm) | 12-3/8" (314 mm) | 2-5/16" (59 mm) | 2-1/8" (54 mm) | 5-3/4" (146 mm) | 5-3/4" (146 mm) | 19 kips (85 kN) | 9.5 kips (42 kN) | 9.5 kips (42 kN) | 15" (381 mm) | 18" (457 mm) |
| 1-1/4" (32 mm) | 0.440" (11 mm) | 12-1/2" (318 mm) | 2-1/2" (64 mm) | 2-1/8" (54 mm) | 5-3/4" (146 mm) | 5-3/4" (146 mm) | 32 kips (142 kN) | 14 kips (60 kN) | 14 kips (60 kN) | 20" (508 mm) | 24" (610 mm) |
| 1-1/2" (38 mm) | 0.375" (9.5 mm) | 12-3/8" (314 mm) | 2-9/16" (65 mm) | 2-1/8" (54 mm) | 5-3/4" (146 mm) | 5-3/4" (146 mm) | 19 kips (85 kN) | 9.5 kips (42 kN) | 9.5 kips (42 kN) | 15" (381 mm) | 18" (457 mm) |
| 1-1/2" (38 mm) | 0.440" (11 mm) | 12-1/2" (318 mm) | 2-3/4" (70 mm) | 2-1/8" (54 mm) | 5-3/4" (146 mm) | 5-3/4" (146 mm) | 32 kips (142 kN) | 14 kips (60 kN) | 14 kips (60 kN) | 20" (508 mm) | 24" (610 mm) |

See Notes on page 27.

Heavy Criss Cross Coil Loop Insert

The Heavy Criss Cross Flared Coil Loop Insert has three flared loop struts welded to the coil for greater load distribution and shear capacity. It is available in 1-1/4" bolt diameter x 15" long. Numbers shown are based a 2:1 safety factor.

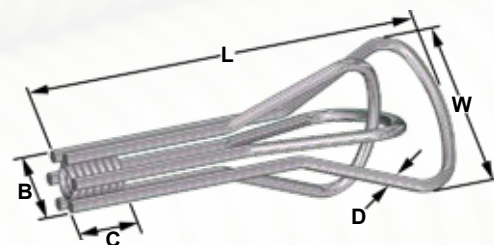

| Bolt Diameter | Wire Diameter | Overall Length | Flare Spread | Minimum Edge Distance | Safe Working Load |
|----------------|----------------|----------------|--------------|-----------------------|-------------------|
| 1-1/4" (32 mm) | 0.440" (11 mm) | 15" (381 mm) | 6" (152 mm) | 21" (533 mm) | 48 kips (214 kN) |

See Notes on page 27.

C18 Coil Wingnut Insert

The Coil Wingnut Insert is designed for use in thin slabs or small sections to attach secondary items or they can be used as nut on a length of coil rod in forming applications. Refer to the chart for diameters, dimensions and safe working loads. Numbers shown are based a 2:1 safety factor.

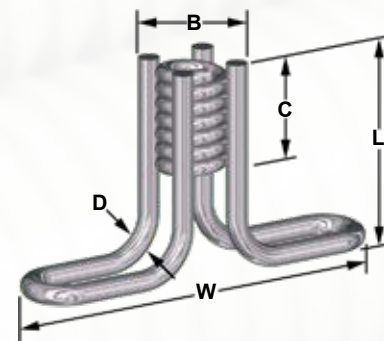

| Bolt Diameter | Wire Diameter (D) | Overall Length (L) | Width (B) | Coil Length (C) | Flare Width (W) | Safe Working Loads | | | Edge Distance | |
|---------------|-------------------|--------------------|----------------|-----------------|-----------------|--------------------|--------------------|-------------------|---------------|--------------|
| | | | | | | Forming (2:1 SF) | Tension (4:1 SF) | Shear (4:1 SF) | Tension | Shear |
| 1/2" (13 mm) | 0.225" (5.7 mm) | 2-1/4" (57 mm) | 1-1/4" (32 mm) | 1-3/16" (30 mm) | 4-1/8" (105 mm) | 1.9 kips (8.5 kN) | 0.95 kips (4.2 kN) | 1.1 kips (4.9 kN) | 4" (102 mm) | 6" (152 mm) |
| 3/4" (19 mm) | 0.262" (6.65 mm) | 2-1/4" (57 mm) | 1-1/2" (38 mm) | 1-5/8" (41 mm) | 5" (127 mm) | 4.0 kips (18 kN) | 2.0 kips (8.9 kN) | 1.3 kips (5.6 kN) | 5" (127 mm) | 5" (127 mm) |
| 3/4" (19 mm) | 0.306" (7.77 mm) | 3-1/2" (89 mm) | 1-5/8" (41 mm) | 1-5/8" (41 mm) | 6" (152 mm) | 6.8 kips (30 kN) | 3.4 kips (15 kN) | 2.5 kips (11 kN) | 6" (152 mm) | 9" (229 mm) |
| 1" (25 mm) | 0.306" (7.77 mm) | 2-1/2" (64 mm) | 2" (51 mm) | 2" (51 mm) | 6" (152 mm) | 4.0 kips (18 kN) | 2.0 kips (8.9 kN) | 2.0 kips (8.9 kN) | 5" (127 mm) | 6" (152 mm) |
| 1" (25 mm) | 0.306" (7.77 mm) | 4-1/2" (114 mm) | 2" (51 mm) | 2" (51 mm) | 6" (152 mm) | 9.5 kips (42 kN) | 4.75 kips (21 kN) | 3.9 kips (17 kN) | 8" (203 mm) | 12" (305 mm) |



Coil & Ferrule Inserts

C17 Thin Slab Lifting Insert

The Thin Slab Insert is a four-strut insert fabricated from deformed wire or increased pullout strength. It is available in 3/4" through 1-1/2" diameters. The limited height of the insert makes it effective in thin concrete applications. Numbers shown are based a 2:1 safety factor.

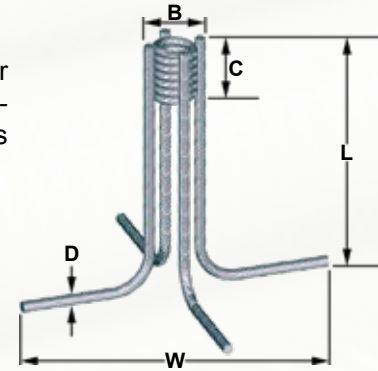

| Bolt Diameter | Wire Diameter (D) | Overall Length (L) | Width (B) | Coil Length (C) | Flare Width (W) | Safe Working Loads | | | Edge Distance | |
|-------------------|---------------------|--------------------|-------------------|-------------------|--------------------|---------------------|----------------------|----------------------|-----------------|-----------------|
| | | | | | | Forming (2:1 SF) | Tension (4:1 SF) | Shear (4:1 SF) | Tension | Shear |
| 3/4" (19 mm) | 0.306" (7.77 mm) | 3" (76 mm) | 1-5/8" (41 mm) | 1-3/4" (45 mm) | 7-1/8" (181 mm) | 5.0 kips (22 kN) | 2.5 kips (8.9 kN) | 2.0 kips (8.9 kN) | 9" (229 mm) | 9" (229 mm) |
| 1" (25 mm) | 0.306" (7.77 mm) | 4" (102 mm) | 1-7/8" (48 mm) | 2-1/8" (54 mm) | 9-1/2" (241 mm) | 7.0 kips (31 kN) | 3.5 kips (16 kN) | 3.5 kips (16 kN) | 12" (305 mm) | 13" (330 mm) |
| 1-1/4" (32 mm) | 0.375" (9.5 mm) | 4" (102 mm) | 2-1/4" (57 mm) | 2-1/8" (54 mm) | 9-3/4" (248 mm) | 8.0 kips (36 kN) | 4.0 kips (15 kN) | 4.0 kips (15 kN) | 12" (305 mm) | 14" (356 mm) |
| 1-1/2" (38 mm) | 0.375" (9.5 mm) | 4" (102 mm) | 2-1/2" (64 mm) | 2-1/8" (54 mm) | 10" (254 mm) | 8.0 kips (36 kN) | 4.0 kips (15 kN) | 4.0 kips (15 kN) | 12" (305 mm) | 14" (356 mm) |

F10 Standard Ferrule Insert

The Standard Ferrule Insert is machined from solid 12L14 bar stock and is available in the bolt diameters shown in the table. All Williams ferrules have standard NC threads and have a closed end to prevent concrete seeping into the ferrule. Minimum bolt engagement for all standard ferrules is bolt diameter plus 1.8". Ferrules with an open end and ferrules in lengths other than those shown in the tables are available on special order. The Standard Ferrule Insert is available in plain hot dip galvanize finish. Type 304 stainless steel is available on special order only.

| Bolt Diameter | Pitch | Maximum Bolt Engagement | Width (B) | Length (L) |
|-------------------|-------|-------------------------|---------------------|-------------------|
| 3/8" (9.5 mm) | 16 | 3/4" (20 mm) | 9/16" (14 mm) | 1-1/4" (32 mm) |
| 1/2" (13 mm) | 13 | 1" (25 mm) | 11/16" (17 mm) | 1-3/8" (35 mm) |
| 5/8" (16 mm) | 11 | 1-1/8" (29 mm) | 7/8" (22 mm) | 1-5/8" (41 mm) |
| 3/4" (19 mm) | 10 | 1-1/8" (29 mm) | 1" (25 mm) | 1-5/8" (41 mm) |
| 7/8" (22 mm) | 9 | 1-1/8" (29 mm) | 1-3/8" (35 mm) | 1-5/8" (41 mm) |
| 1" (25 mm) | 8 | 1-1/8" (29 mm) | 1-3/8" (35 mm) | 1-5/8" (41 mm) |
| 1-1/4" (32 mm) | 7 | 2" (51 mm) | 1-11/16" (68 mm) | 2-1/2" (64 mm) |
| 1-1/2" (38 mm) | 6 | 2" (51 mm) | 2" (51 mm) | 2-1/2" (64 mm) |

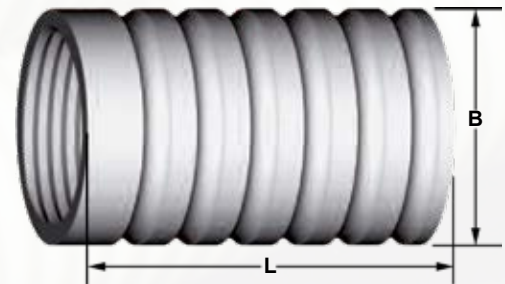

Notes for all Ties and Inserts

- Numbers shown are based on minimum concrete strength of 3,000 PSI.
- Safe working loads are based on 2:1 safety factor for forming and 4:1 safety factor for tension and shear.
- Inserts must have a 1/2" setback from the surface of the concrete and sufficient coil penetration by the lifting bolt.
- Minimum concrete thickness = L + setback + 3/4" clear cover.
- Minimum edge distance apply to 2 edges only. All other edges require 2x length of insert.
- Minimum corner distance shall be 1.5x minimum edge distance for shear when loaded towards the edge.
- Minimum anchor spacing shall be 2x the edge distance for forming and tension and 3x the edge distance for shear.
- Anchors with asterisks exceed the shear capacity of the coil rod.
- Coil Inserts & Ties are available in plain, hot dip galvanize, or stainless steel finish.
- See Page 21 for optional Coil Tie accessories.

WARNING: Minimum coil penetration is extremely important and must be adhered to when threading Coil Bolts into other coil-threaded products. Safe working loads are dependent on maintaining the appropriate minimum coil penetration; failure to do so can lead to a premature failure of the coil and compromise worker safety. Refer to the tables for safe working loads and minimum coil penetration lengths.



Ferrule Inserts

F22 Open Ferrule Insert

The Open Ferrule Insert is a high strength, highly versatile insert available for numerous precast concrete applications. It is available in 3/4" through 1-1/2" bolt diameters and in the different lengths displayed in the table. The insert is constructed with a NC threaded coil, shaped struts (two strut shown below, also available with four or six depending on the model) and an expanded wire coil. The efficient design increases the shear cone surface area thus increasing the load capacity of the insert. The Open Ferrule Insert is available with an optional mounting washer for easy nailing to the form. The insert is available in plain and hot dip galvanize finish. Safe Working Loads shown are based on 3,000 PSI concrete and a 3:1 safety factor.

| Bolt Diameter | Wire Diameter (D) | Overall Length (L) | Width (B) | Tap Length (C) | Open Width (W) | Safe Working Load | | Edge Distance | |
|-------------------|--------------------|--------------------|---------------------|-------------------|-------------------|---------------------|-----------------------|-----------------|-----------------|
| | | | | | | Tension (3:1 SF) | Shear (3:1 SF) | Tension | Shear |
| 3/4" (19 mm) | 0.375" (9.5 mm) | 4-1/2" (144 mm) | 1-11/16" (43 mm) | 1-5/8" (41 mm) | 2-3/8" (60 mm) | 5.7 kips (25 kN) | 5.7 kips (25 kN) | 7" (178 mm) | 12" (305 mm) |
| 7/8" (22 mm) | 0.440" (11 mm) | 5-1/2" (140 mm) | 2-3/16" (56 mm) | 1-5/8" (41 mm) | 2-7/8" (64 mm) | 8.3 kips (37 kN) | 8.3 kips (37 kN) | 9" (229 mm) | 16" (406 mm) |
| 1" (25 mm) | 0.440" (11 mm) | 5-1/2" (140 mm) | 2-3/16" (56 mm) | 1-5/8" (41 mm) | 2-7/8" (64 mm) | 8.3 kips (37 kN) | 8.3 kips (37 kN) | 9" (229 mm) | 16" (406 mm) |
| 1" (25 mm) | 0.440" (11 mm) | 7-1/2" (191 mm) | 2-3/16" (56 mm) | 1-5/8" (41 mm) | 2-7/8" (64 mm) | 13 kips (59 kN) | 16 kips (71 kN) | 12" (305 mm) | 24" (610 mm) |
| 1-1/4" (32 mm) | 0.440" (11 mm) | 7-1/2" (191 mm) | 2-1/2" (64 mm) | 2-1/2" (64 mm) | 3-1/8" (80 mm) | 16 kips (71 kN) | 16 kips (71 kN) | 13" (305 mm) | 24" (610 mm) |
| 1-1/4" (32 mm) | 0.440" (11 mm) | 9-1/2" (241 mm) | 2-1/2" (64 mm) | 2-1/2" (64 mm) | 3-1/8" (80 mm) | 21 kips (95 kN) | 21 kips (96 kN) | 16" (406 mm) | 26" (660 mm) |
| 1-1/2" (38 mm) | 0.440" (11 mm) | 9-1/2" (241 mm) | 2-13/16" (71 mm) | 2-1/2" (64 mm) | 3-3/8" (86 mm) | 21 kips (95 kN) | 21.65 kips (96 kN) | 16" (406 mm) | 26" (660 mm) |



F16 Ferrule Loop Insert

The Ferrule Loop Insert is a versatile insert commonly used to make structural connections and to suspend pipes and/or other mechanical equipment. Refer to the table for bolt diameters and dimensions. The insert is available in plain or hot dip galvanize finish. Safe Working Loads shown are based on 3,000 PSI concrete and a 3:1 safety factor.

| Bolt Diameter | Wire Diameter (D) | Overall Length (L) | Width (B) | Tap Length (C) | Inner Radius (R) | Safe Working Load | | Edge Distance | |
|------------------|---------------------|--------------------|--------------------|-------------------|-------------------|----------------------|----------------------|----------------|-----------------|
| | | | | | | Tension (3:1 SF) | Shear (3:1 SF) | Tension | Shear |
| 3/8" (9.5 mm) | 0.243" (6.2 mm) | 2-3/4" (70 mm) | 1-1/16" (27 mm) | 1-1/4" (32 mm) | 9/16" (14 mm) | 2.0 kips (8.9 kN) | 2.0 kips (8.9 kN) | 5" (125 mm) | 8" (203 mm) |
| 1/2" (13 mm) | 0.243" (6.2 mm) | 2-3/4" (70 mm) | 1-1/8" (29 mm) | 1-3/8" (35 mm) | 9/16" (14 mm) | 2.0 kips (8.9 kN) | 2.0 kips (8.9 kN) | 5" (125 mm) | 8" (203 mm) |
| 5/8" (16 mm) | 0.262" (6.65 mm) | 3-1/2" (89 mm) | 1-1/2" (38 mm) | 1-5/8" (41 mm) | 13/16" (21 mm) | 2.3 kips (10 kN) | 2.3 kips (10 kN) | 5" (125 mm) | 12" (305 mm) |
| 3/4" (19 mm) | 0.262" (6.65 mm) | 3-1/2" (89 mm) | 1-3/4" (45 mm) | 1-5/8" (41 mm) | 13/16" (21 mm) | 2.4 kips (11 kN) | 2.4 kips (11 kN) | 5" (125 mm) | 12" (305 mm) |
| 7/8" (22 mm) | 0.375" (9.5 mm) | 6" (152 mm) | 2-1/16" (52 mm) | 1-5/8" (41 mm) | 1-3/8" (35 mm) | 5.3 kips (24 kN) | 5.3 kips (24 kN) | 8" (203 mm) | 12" (305 mm) |
| 1" (25 mm) | 0.375" (9.5 mm) | 6" (152 mm) | 2-1/8" (54 mm) | 1-5/8" (41 mm) | 1-3/8" (35 mm) | 5.3 kips (24 kN) | 5.3 kips (24 kN) | 8" (203 mm) | 12" (305 mm) |

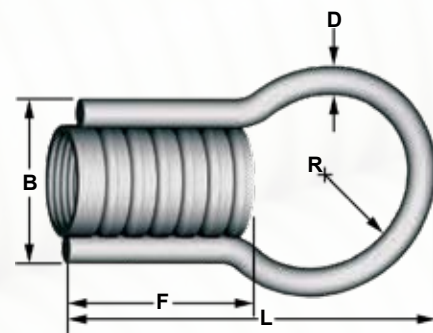

F18 Ferrule Wingnut Insert

The Ferrule Wingnut Insert is also available for use where panel thickness is limited. This insert is available in 1/2" through 1" bolt diameters and offers better tension loads than other thin slab inserts. It is available in plain and hot dip galvanize finish. Safe Working Loads shown are based on 3,000 PSI concrete and a 3:1 safety factor.

| Bolt Diameter | Wire Diameter (D) | Overall Width (W) | Insert Width (B) | Tap Length (C) | Safe Working Load | | Edge Distance | |
|-----------------|---------------------|--------------------|-------------------|-------------------|----------------------|----------------------|----------------|-----------------|
| | | | | | Tension (3:1 SF) | Shear (3:1 SF) | Tension | Shear |
| 1/2" (13 mm) | 0.225" (5.7 mm) | 4-1/2" (115 mm) | 1-1/8" (29 mm) | 1-3/8" (35 mm) | 1.2 kips (5.3 kN) | 1.2 kips (5.3 kN) | 4" (102 mm) | 6" (152 mm) |
| 3/4" (19 mm) | 0.306" (7.77 mm) | 4-7/8" (124 mm) | 1-3/4" (45 mm) | 1-5/8" (41 mm) | 2.7 kips (12 kN) | 1.7 kips (7.3 kN) | 5" (125 mm) | 5" (125 mm) |
| 3/4" (19 mm) | 0.306" (7.77 mm) | 4-7/8" (124 mm) | 1-3/4" (45 mm) | 1-5/8" (41 mm) | 4.5 kips (20 kN) | 3.3 kips (14 kN) | 6" (152 mm) | 9" (229 mm) |
| 1" (25 mm) | 0.375" (9.5 mm) | 5-1/8" (130 mm) | 2-1/8" (54 mm) | 1-5/8" (41 mm) | 4.5 kips (20 kN) | 3.3 kips (14 kN) | 6" (152 mm) | 9" (229 mm) |
| 1" (25 mm) | 0.375" (9.5 mm) | 5-1/8" (130 mm) | 2-1/8" (54 mm) | 1-5/8" (41 mm) | 6.5 kips (29 kN) | 5.2 kips (23 kN) | 8" (203 mm) | 12" (305 mm) |

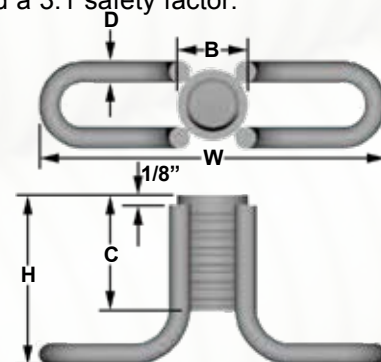



Ferrule Inserts

F15 Straight Ferrule Loop Insert

The Straight Ferrule Loop Inset is a versatile insert commonly used for structural connections and as an anchor for suspension of pipes and/or other mechanical equipment. Refer to the table for bolt diameters and lengths available. The insert is available in plain or hot dip galvanize finish. Safe Working Loads shown are based on 3,000 PSI concrete and a 3:1 safety factor.

| Bolt Diameter | Wire Diameter (D) | Overall Length (L) | Width (B) | Tap Length (C) | Safe Working Load | | Edge Distance | |
|---------------|-------------------|--------------------|------------------|----------------|-------------------|------------------|---------------|--------------|
| | | | | | Tension (3:1 SF) | Shear (3:1 SF) | Tension | Shear |
| 1/2" (13 mm) | 0.225" (5.7 mm) | 4-1/8" (105 mm) | 1-1/16" (27 mm) | 1-3/8" (35 mm) | 3.0 kips (13 kN) | 2.6 kips (11 kN) | 7" (178 mm) | 9" (229 mm) |
| 1/2" (13 mm) | 0.306" (7.8 mm) | 6-1/8" (156 mm) | 1-1/4" (32 mm) | 1-3/8" (35 mm) | 4.0 kips (18 kN) | 4.0 kips (18 kN) | 10" (254 mm) | 10" (254 mm) |
| 5/8" (16 mm) | 0.225" (5.7 mm) | 4-1/8" (105 mm) | 1-1/4" (32 mm) | 1-5/8" (41 mm) | 3.0 kips (13 kN) | 2.6 kips (12 kN) | 7" (178 mm) | 9" (229 mm) |
| 5/8" (16 mm) | 0.375" (9.5 mm) | 6-1/8" (156 mm) | 1-9/16" (40 mm) | 1-5/8" (41 mm) | 5.0 kips (22 kN) | 4.0 kips (18 kN) | 10" (254 mm) | 10" (254 mm) |
| 3/4" (19 mm) | 0.225" (5.7 mm) | 4-1/8" (105 mm) | 1-3/8" (35 mm) | 1-5/8" (41 mm) | 3.0 kips (13 kN) | 3.0 kips (13 kN) | 7" (178 mm) | 10" (254 mm) |
| 3/4" (19 mm) | 0.375" (9.5 mm) | 6-1/8" (156 mm) | 1-11/16" (43 mm) | 1-5/8" (41 mm) | 5.0 kips (22 kN) | 5.6 kips (25 kN) | 10" (254 mm) | 12" (305 mm) |
| 7/8" (22 mm) | 0.375" (9.5 mm) | 6-1/8" (156 mm) | 2" (51 mm) | 1-5/8" (41 mm) | 5.0 kips (22 kN) | 5.6 kips (25 kN) | 10" (254 mm) | 12" (305 mm) |
| 1" (25 mm) | 0.375" (9.5 mm) | 6-1/8" (156 mm) | 2-1/8" (54 mm) | 1-5/8" (41 mm) | 5.0 kips (22 kN) | 6.0 kips (27 kN) | 10" (254 mm) | 12" (305 mm) |
| 1" (25 mm) | 0.375" (9.5 mm) | 8-1/8" (206 mm) | 2-1/8" (54 mm) | 1-5/8" (41 mm) | 6.0 kips (27 kN) | 6.0 kips (27 kN) | 13" (330 mm) | 13" (330 mm) |

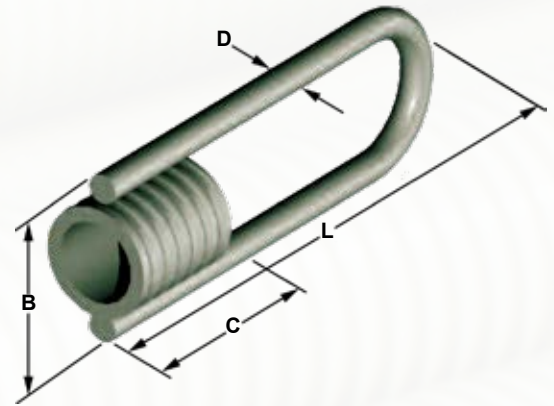

F17 Thin Slab Ferrule Insert

The Thin Slab Ferrule Insert consists of a ferrule and four deformed wire struts. It is designed to attach thin panels to the building frame or to attach or suspend plumbing or mechanical equipment. The insert is available in 3/4" and 1" bolt diameters and in plain or galvanized finish. Safe Working Loads shown are based on 3,000 PSI concrete and a 3:1 safety factor.

| Bolt Diameter | Wire Diameter (D) | Overall Length (L) | Width (B) | Tap Length (C) | Safe Working Load (Tension) | Minimum Edge Distance (Tension) |
|---------------|-------------------|--------------------|-----------------|----------------|-----------------------------|---------------------------------|
| 3/4" (19 mm) | 0.306" (7.8 mm) | 3-1/8" (80 mm) | 7" (175 mm) | 1-5/8" (41 mm) | 3.5 kips (16 kN) | 8" (203 mm) |
| 1" (25 mm) | 0.306" (7.8 mm) | 4-1/8" (105 mm) | 9-1/2" (241 mm) | 1-5/8" (41 mm) | 4.5 kips (20 kN) | 10" (254 mm) |

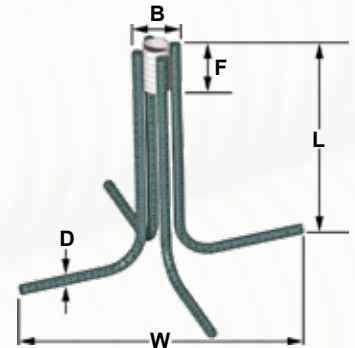

F11 Thin Slab Strut Ferrule Insert

The Thin Slab Strut Ferrule Insert is fabricated with two 4" wire struts welded to a standard ferrule. Sizes and dimensions are shown in the table. This insert is used effectively in small-envelope areas. The Thin Slab Strut Ferrule Insert is available in plain and hot dip galvanize finish. Safe Working Loads shown are based on 3,000 PSI concrete and a 3:1 safety factor.

| Bolt Diameter | Wire Diameter (D) | Width (B) | Tap Height (H) | Safe Working Load (Tension) |
|---------------|-------------------|----------------|----------------|-----------------------------|
| 3/8" (9.5 mm) | 0.262" (6.7 mm) | 9/16" (14 mm) | 1-1/4" (32 mm) | 0.45 kips (2.0 kN) |
| 1/2" (13 mm) | 0.262" (6.7 mm) | 11/16" (18 mm) | 1-3/8" (35 mm) | 0.9 kips (4.0 kN) |
| 5/8" (16 mm) | 0.262" (6.7 mm) | 7/8" (22 mm) | 1-5/8" (41 mm) | 1.0 kips (4.5 kN) |
| 3/4" (19 mm) | 0.262" (6.7 mm) | 1" (25 mm) | 1-5/8" (41 mm) | 1.6 kips (7.1 kN) |
| 7/8" (22 mm) | 0.262" (6.7 mm) | 1-3/8" (35 mm) | 1-5/8" (41 mm) | 1.6 kips (7.1 kN) |
| 1" (25 mm) | 0.262" (6.7 mm) | 1-3/8" (35 mm) | 1-5/8" (41 mm) | 1.6 kips (7.1 kN) |

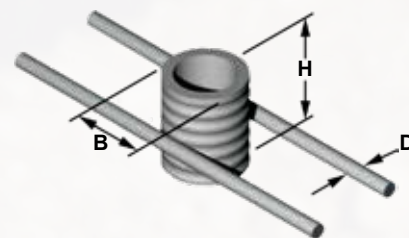



Panel Ties

A14 Regular & A15 Heavy Standard Loop Tie



The ST-23 & ST-24 Loop Tie is designed for use with modular forming systems. It is available in standard and heavy versions and is supplied with 2-1/8" ends to accept the standard modular form wedge bolt. Both come with a 1" breakback and without spreaders. The ST-23 Standard Loop Tie has a Safe Working Load of 2,250 lbs and ST-24 Heavy Loop Ties have a SWL of 3,000 lbs. Both are based on an approximate 2:1 Safety Factor.

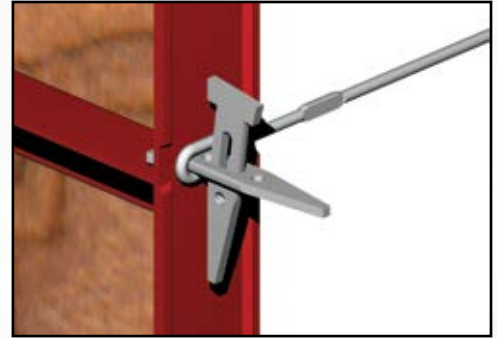

A16 Regular & A17 Heavy Gang Tie



The fabrication and use of the Gang Tie is similar to the Loop Tie, except the end dimension has been increased to 4-15/16". The longer end dimension is designed to accept the typical modular forming gang wedge bolt. The longer end dimension allows the gang tie to be broken back before the formwork is stripped. The Standard Gang Tie has a SWL of 2,250 lbs and the Heavy Gang Tie has a SWL of 3,000 lbs. Both are based on an approximate 2:1 Safety Factor.

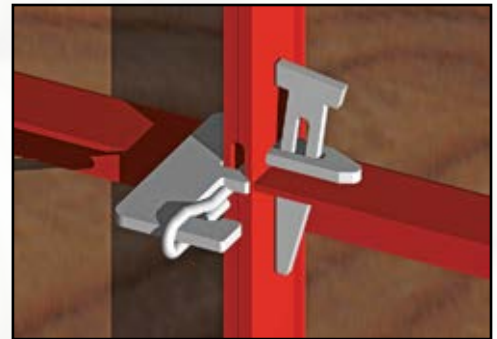

A18 Regular & A19 Heavy Plastic Cone Loop Tie

The Plastic Cone Loop Ties are similar to the standard Loop Ties, but are equipped with 1" plastic spreader cones and 1" breakback. The Standard Loop Tie w/ Plastic Cone has a Safe Working Load of 2,250 lbs and the Heavy Loop Tie w/ Plastic Cone has a SWL of 3,000 lbs. Both are based on an approximate 2:1 Safety Factor.

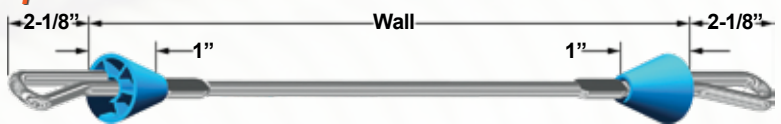

Strongback Tie



The Strongback Tie is designed for use in conjunction with a Waler Holder to attach the wales and double vertical strongbacks to modular forms. Strongback Ties are available in three lengths to accommodate various lumber combinations, as noted in the table.

| Lumber Dimension | Overall Length |
|--------------------------------|----------------|
| 2x4 Wales plus 2x4 Strongbacks | 9-3/4" |
| 2x4 Wales plus 2x6 Strongbacks | 11-5/8" |
| 2x6 Wales plus 2x6 Strongbacks | 13-1/2" |



Waler Tie



The Waler Tie is similar to the Strongback Tie but has its ends turned 90 to attach double wales to the modular form. The Waler Tie is available in two lengths to accommodate 2x4 and 2x6 double horizontal wales.

| Lumber Dimension | Overall Length |
|------------------|----------------|
| Double 2x4 Wales | 6-3/16" |
| Double 2x6 Wales | 8-1/32" |





Panel Ties

Wedge Bolt

The Wedge Bolt is designed to be used in pairs to securely attach and hold adjacent modular forms and a loop tie together.



Gang Wedge Bolt

The Gang Wedge Bolt is designed to hold adjacent modular forms together in combination with a Gang Tie. This provides a means of tie breakback prior to form removal.

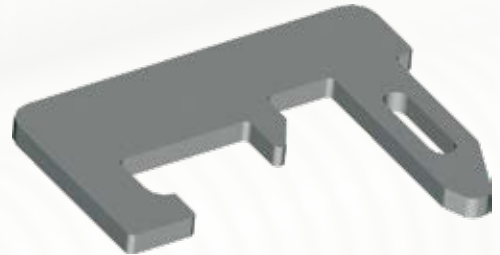

Waler Holder

The Waler Holder is designed to attach to a modular form with a Waler Tie and securely support and tie double walers to the form.



Standard Flat Tie

The Flat Tie is designed for use on most standard modular forming systems. Both the Standard and Heavy versions utilize Wedge Bolts to secure the formwork. Standard and Heavy Flat Ties are available in lengths 6" to 36" in 2" increments. Breakback is 1/4". Other lengths available on special order. The Standard Flat Tie has a Safe Working Load of 2,250 lbs and the Heavy Flat Tie has a SWL of 3,000 lbs. Both are based on an approximate 2:1 Safety Factor.



Duo Flat Tie

The Duo Flat Tie is similar to the Standard Flat Tie in design and use, but has two slot holes outboard of the breakback point. This feature allows for the combination use of modular and wood forming elements. Duo Flat Ties are available in standard and heavy versions and have a normal 1/4" breakback. The Standard Duo Flat Tie has a Safe Working Load of 2,250 lbs and the Heavy Duo Flat Tie has a SWL of 3,000 lbs. Both are based on an approximate 2:1 Safety Factor.



Type "M" Flat Tie

The Type M Flat Tie is similar in design, construction and use to the Standard Flat Tie, but has ends that are 5/8" shorter. Type M Flat Ties are available in standard and heavy versions and have a 1/4" breakback. The Standard Type M Flat Tie has a Safe Working Load of 2,250 lbs and Heavy Type M Flat Tie has a SWL of 3,000 lbs. Both are based on an approximate 2:1 Safety Factor.





Single Waler System

The Single Waler System is an economical, modern wall forming method designed for use on straight, battered, curved and rounded walls and with various beam forms.

Whether your forming needs are for a four-foot knee wall or a twelve-foot retaining wall, the Single Waler System can accommodate all of your hand-set light forming requirements.

The complete system includes:

- Plastic cone or loose metal washer snapties with 4-3/4" ends
- Single Waler Bracket
- Form Aligner Clamp for strongbacks
- Snap Jack for walls over 8' high
- Form Aligner Brace



Snap Bracket

The Snap Bracket is the key element of the Single Waler System. It is fabricated from heavy gauge steel and cadmium-plated for high corrosion resistance. This versatile bracket can be installed horizontally, vertically or even inverted with a 2x4 kicker plate. The Snap Bracket uses 4-3/4" L & W snapties and its sliding wedge has a 5/8" adjustment range for minor lumber variation.

The brackets can be installed before or after the wales have been placed and have a unique waler alignment feature not available on other brackets. Nailing the bracket and/or wedge to the wales is not required, but nail holes are provided and strategically placed, if needed.

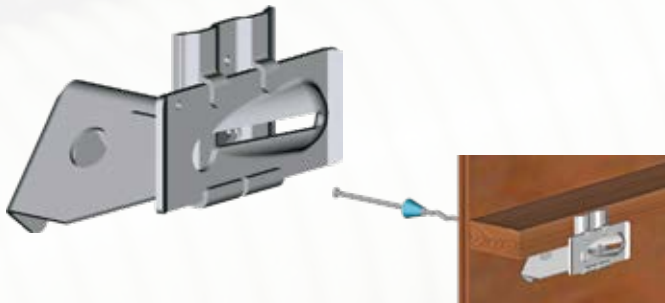

Form Aligner Clamp

The Form Aligner Clamp provides the Single Waler System with a fast and easy way to attach 2x4 strongbacks to the form. The galvanized clamp can be installed vertically or horizontally at any point on the form.



"A" Bracket

The (Jahn) "A" Brackets are made of high strength steel with a cadmium plated eccentric and a rust-resistant painted body. Designed for use with a single 2x4 waler, the bracket is used to hold either a single horizontal wale, or a single vertical stud. The bracket can be installed either before or after walers are in place. Slots in the bracket allow it to slip over the snap tie end. Loading from the bracket is against the 2x4 instead of the plywood. The "A" bracket uses 4-3/4" L & W snap ties. Bracket will not loosen from internal vibration of the concrete.



"C" Bracket

The (Jahn) "C" Bracket is used to attach single 2x4 studs and double vertical strongbacks for formwork alignment. Also engineered for use with double wales to support a horizontal plywood joint. Uses 8-1/4" L & W snap ties.





Single Waler System

Snap Jack

The Snap Jack is an integral part of the Single Waler System and is used when forming walls over 8' high to support a work platform. The steel one-piece unit quickly attaches to a Single Waler Bracket. Reference the installation sequence below. The Snap Jack has a built-in guardrail adapter to accept 2x4 guardrails. The lower support angle is provided with nail holes in order to nail the jack to the waler for added safety. The Snap Jack works with both the Single Waler Bracket and the "A" Bracket.

Safe working load is 800 lbs. Based on an approximate 4:1 safety factor. Do not, under any circumstances, place the Scaffold Jacks more than 8' apart. Consult a Williams representative with questions concerning special load design applications.



Snap Jack Installation

1. The Snap Jack must be installed between and into two Single Waler Brackets.
2. Insert one end of the Snap Jack bar into one of the Single Waler Brackets. Slide the bar through the bracket until the opposite end of the bar clears the second bracket.
3. Next slide the Snap Jack bar into and through the second bracket. Make sure that the bar extends past each of the brackets at least 2". Center the Snap Jack between the two brackets and nail the lower support angle to the waler.



F8Z Form Aligner Braces

The Form Aligner Braces are designed to brace and align vertical formwork. The standard brace consists of a length of angle iron, a self-cleaning turnbuckle and a steel toe plate. The angle iron is equipped with nail holes allowing the brace to be attached to a 2x4 or 2 x 6 to extend the reach of the brace. The turnbuckle is fabricated with coil threads for quick and easy adjustments and the steel toe plate can accept a round steel stake, be nailed to a wood stake or be inverted and nailed directly to a stud or wales. The Form Aligner Brace is equipped with a spade-type toe plate designed for use with modular forms and wedge bolts.

The safe working load for the brace is determined by the method of attachment and the extension lumber used.



Waler Spacing & Tie Alignment

Misalignment of walers can cause Snapties to bend. Bent Snapties will not carry the expected design loads and a premature failure may result.

Wales must be continuous with joints staggered. Do not omit any walers. Omitting one of a double waler set will cause load redistribution and can result in a tie failure. All walers must be in place and all ties must be positioned properly.

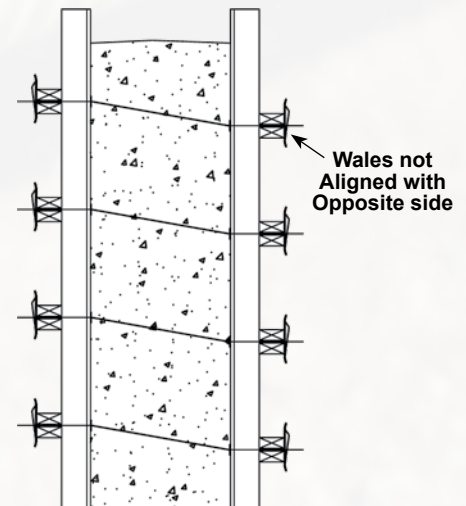



Single Waler Forming Application

Gang Drilling Plywood

Gang drilling is a quick and economical way to prepare plywood for the single waler forming application. Simply stack the plywood and drill the tie holes with a 5/8" drill bit. The System works equally well with a 5/8" or 3/4" plywood. The wedge take-up in the bracket will compensate for the difference in plywood thickness.

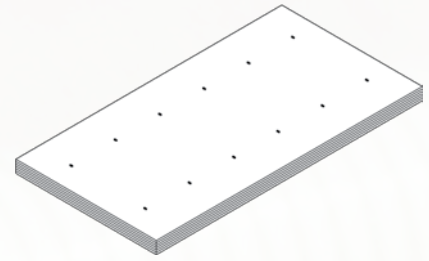

Common Spacing Layouts

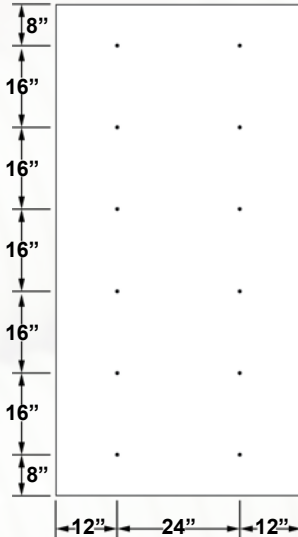

12 Holes

You can minimize the amount of ties required with this standard spacing layout. You can also eliminate the need of a starter plate on 8' walls. NOTE: For L/360 deflection, use 12" waler spacing.

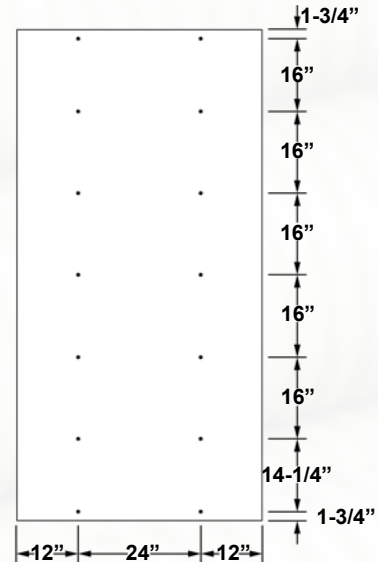

14 Holes

This pattern is required for walls over 8' or when panels are to be attached to a kicker plate with inverted brackets. With this panel layout, the top waler is used to start the next tier of panels.

Wall Height Considerations

Snaptie spacing is dependent upon form pressure and the type of forming used. Below are a few typical wall form spacing diagrams for various wall heights with pertinent notes for each height.

- Install 4'x8' plywood horizontally. Attach 2x4 walers with horizontal tie-spacing of 2'-0" on center.

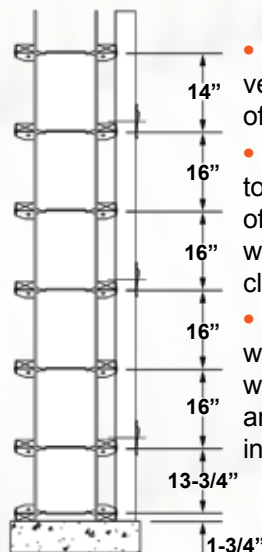
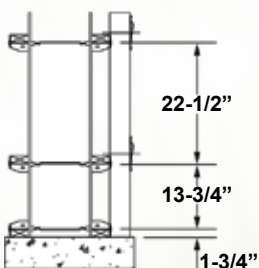

- Attach strong-backs vertically to full height of form.
- Use proper spacing to engage next row of ties, while attaching waler with form aligner clamps.
- Easily attach plywood and secure with wrench head snapties and single waler forming brackets.

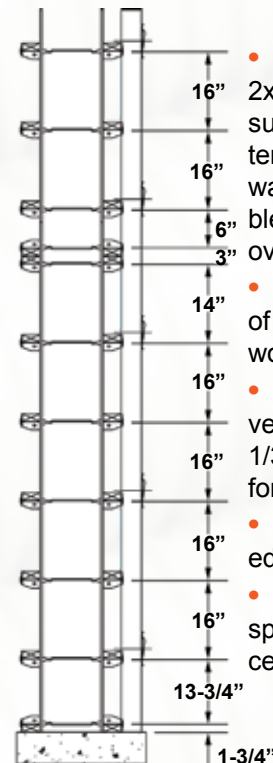

- Single or Double 2x4 strongbacks with support clamps fastened to every other waler provides a stable alignment for walls over 10 ft.
- Nail a waler to top of last waler at plywood joint.
- Nail aligner brace to vertical strongback at 1/3 height from top of form.
- Only one side needed for bracing.
- Form aligner brace spacing at 6 ft. on center.

Single Waler Bracket Installation



1. Install panels over snapties on opposite side and repeat steps 5 and 6.

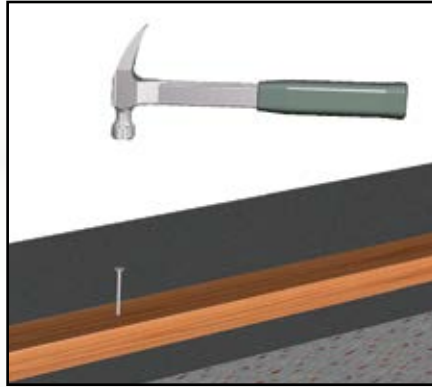

2. (OPTIONAL) For wall over 8 ft. high, nail a 2x4 on top of last waler to act as kicker plate.

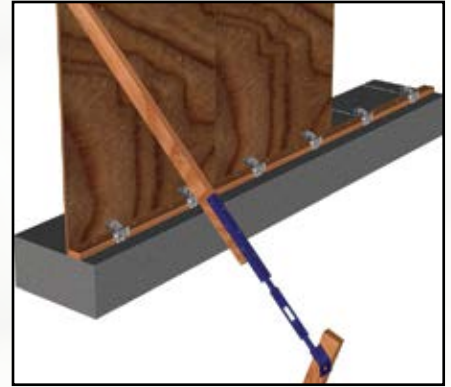

3. Nail vertical plywood panels to 2x4 kicker plate. (Or attached to inverted single waler brackets on kicker plate – brace panels temporarily, as needed.)

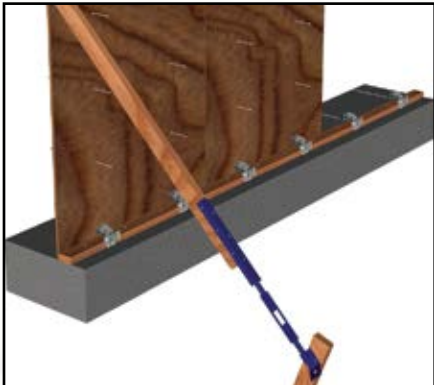

4. Place Snapties through pre-drilled panels from inside of form.

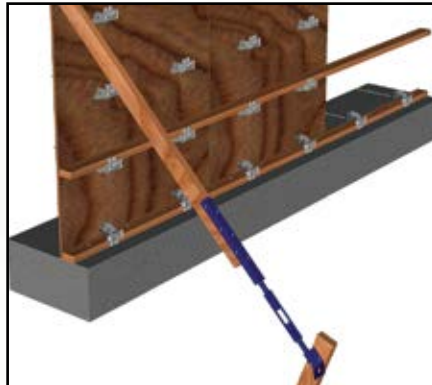

5. Attach Single Waler Brackets on snapties. Do not need to tighten an entire row before installing 2x4 waler. Repeat process for following rows.



6. Tap Single Walers with hammer to tighten. Place 2x4 strongbacks (if desired) and secure with Form Aligner Clamps.

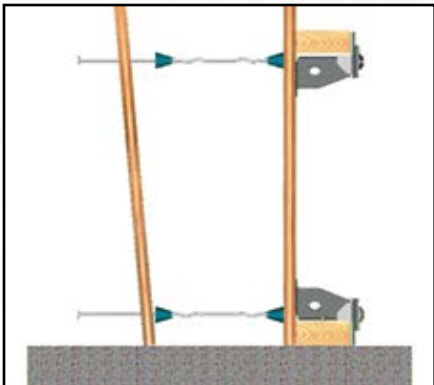

7. Install panels over snapties on opposite side and repeat steps 5 and 6.

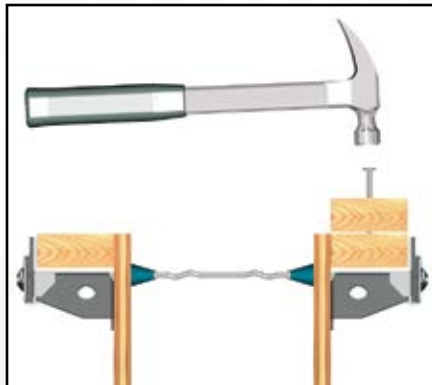

8. (OPTIONAL) For wall over 8 ft. high, nail a 2x4 on top of last waler to act as kicker plate.

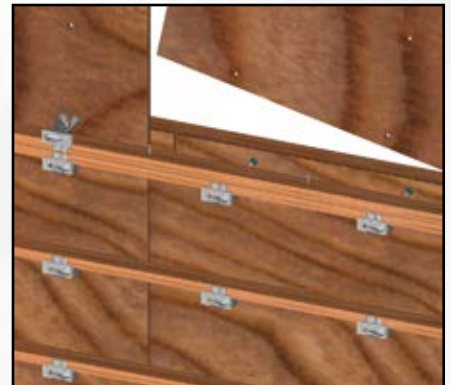

9. Following step 8, align above plywood panels against new top kicker plate and repeat steps 3 through 7. (Scaffolding required) See Snap Jack instructions.



Snapties

A11 Standard Round Head Snapties

The Standard Snaptie has round heads, anti-turn deformations and 1" breakback. A 1/2" breakback is available on special order. The Snaptie is available equipped with either plastic spreader cones or loose metal washers. For additional rust and corrosion resistance, the Standard Snaptie is available in stainless steel. Standard Snapties have a safe working load of 2,250 lbs. based on a 2:1 safety factor.

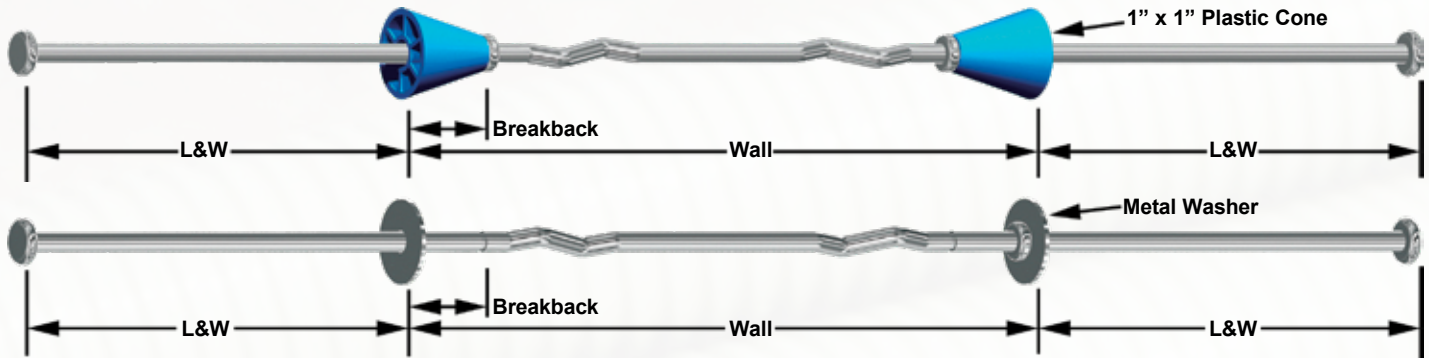

A13 Heavy Snapties

The Heavy Snaptie incorporates all of the same design features of the standard snaptie but is fabricated from high carbon steel to produce a higher safe working load. It is available with plastic cones or loose metal washers. Heavy Snapties have a safe working load of 3,250 lbs. based on a 2:1 safety factor.

Note: Due to factors that affect the ability of a loose metal washer snaptie to breakback, Williams does not guarantee the breakback performance of the loose washer snaptie. Attempting to breakback any tie, before the concrete has been allowed to properly set, may result in the entire tie turning freely in the wall, making the normal breakback procedure no longer possible.

Standard Hex Head Snapties

The Hex Head Snaptie, (previously known as Wrench Head) provides an effective way to breakback snapties before the formwork has been stripped. The head of the snaptie is grasped by the Hex Head Socket and with a simple turning motion, breaks off the end of the snaptie. Removing the snaptie ends in this manner increases the ease and speed of the form stripping operation. Standard Snapties have a safe working load of 2,250 lbs. based on a 2:1 safety factor.



Thread One End Snapties

The Threaded One End Snaptie is manufactured with 1/4" - 20 threads x 2" length on one end and a standard hot forged head on the opposite end. The tie is available with either a plastic spreader cone or a loose metal washer and is used when walls have a variable thickness. A small channel can be installed on either end and then used as a welding tie. Threaded One End Snapties have a safe working load of 250 lbs. based on a 2:1 safety factor.



Snaptie Reminders

- Do not climb on Snapties in the form.
- Do not over-tighten the tie wedges. This can cause severe pre-loading and premature failure.
- Do not place concrete in just one area of the form and allow it to exceed the design pour rate.
- Do not attempt to move the concrete laterally in the form with a vibrator.
- Do not drop the wet concrete more than 30" when placing into the form. This will result in aggregate segregation and unnecessary dangerous impact and loading.
- Do not install bent or damaged ties.
- Do not allow Snaptie ends to remain in the wall beyond 24 hours. Remove the breakback portion of the tie as soon as reasonably possible.
- Do not skip or omit any studs or wales. This will likely cause a premature form failure.
- Do not weld Snapties to any object.



Snapties

Nail Point Snapties

The Nail Point Snaptie is designed to have the nail point driven into the formwork and secured with a fence staple. The tie is available with either a plastic spreader cone or a loose metal washer. The plastic cone snaptie is furnished with a standard 1" breakback and the loose metal washer application has a 1/2" breakback. Nail Point Snapties have a safe working load of 250 lbs. based on a 2:1 safety factor.

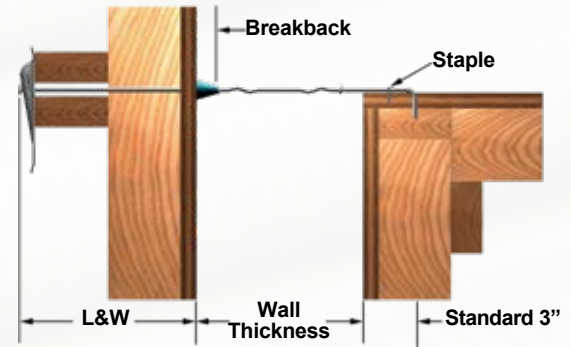
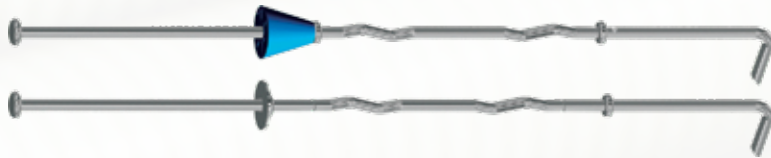

Hooked Snapties

The Hooked Snaptie is designed to attach formwork to a structural beam. The hook end of the tie fits over the flange of the beam and should be tack-welded on the underside of the beam flange for added security. They are available with either a plastic spreader cone or a loose metal washer. Hooked Snapties have a safe working load of 250 lbs. based on a 2:1 safety factor.

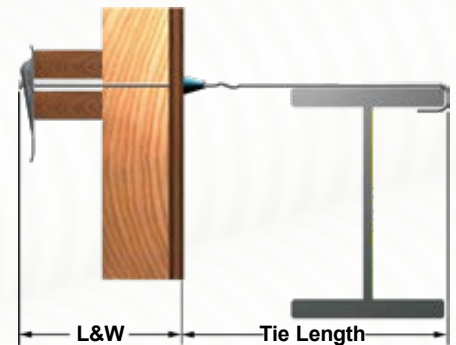

Spandrel Plate Snapties

The Spandrel Plate Snaptie is manufactured with a 16 gauge steel plate with four 1/8" nail holes for nailing direct to formwork. This tie is used similarly to the Nail Point Snaptie. Nail Point Snapties have a safe working load of 250 lbs. based on a 2:1 safety factor.



Residential Snapties

The Residential Snaptie is designed to be used on stem-type footing walls, foundation walls, and basement walls. They are available with fixed 1-1/4" washers for a flush break back. This breakback routinely results in the wire being flush with the surface of the concrete or slightly protruding outside the surface. When a finished wall is desired, this tie is also available with a 1" cone and a 1" breakback. With an end dimension of 1-5/8", the Residential Snaptie can be used with Steel Wedges. Residential Snapties have a safe working load of 2,250 lbs. based on a 2:1 safety factor.



Steel Wedge

The Steel Wedge accommodates either standard or heavy snapties and is designed with sufficient strength to distribute the form loads to the wales. It has a safe working load of 3,250 lbs. based on a 2:1 safety factor.



Snaptie Waterseal

All Snapties are available with a neoprene washer to aid in preventing moisture seepage along the tie wire. Specify this feature when ordering a snaptie product.



A26 Snaptie Wrench

The Snaptie Wrench is used to quickly and easily breakback snapties. After the forming has been stripped, the Snaptie Wrench captures the snaptie end. The tie is bent down to a position nearly parallel to the face of the concrete and a subsequent clockwise rotation of the wrench breaks the tie at the breakback point.

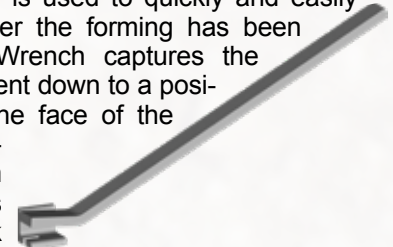

Cautions: Excessive spacing between the walers may cause the steel wedge to bend and result in the cone or washer on the snaptie to become embedded in the concrete. Breakback of the snaptie would be made difficult to accomplish. Over-tightening the wedge may damage the head of the snaptie, the wedge slot and/or the plastic cone and result in a premature failure. The Steel Wedge is designed to carry the load at the upper 2/3 of the wedge slot. Load applied too low on the wedge slot may cause the wedge to deform or break. Nail holes are provided to allow the wedge to be firmly secured to the walers to prevent loosening during vibration.



Accessories

A25 Hex Head Socket

The 3/8" drive Hex Head Socket fits securely over the head of the Hex Head Snaptie. Used primarily on the Single Waler System's short end snapties, a small turn of the socket snaps the tie end at the breakback point before the formwork is removed.



Plylag

The Plylag is designed to firmly attach wales and/or strongbacks to modular forms or to provide an attachment method for coil threaded products. The Plylag is available in 1/2" diameter. Safe working load is based on approximate 2:1 safety factor.

| Overall Length | Threaded Length |
|---------------------|-------------------|
| 6-1/4" (159 mm) | 3-1/2" (89 mm) |
| 6-3/4" (171 mm) | 4" (102 mm) |
| 9-3/4" (248 mm) | 7" (178 mm) |
| 14-3/4" (375 mm) | 12" (305 mm) |



B11 Fitting Up Bolt & Nut

Designed to make assembly and disassembly of steel forms less time consuming. The special tapered point acts as an aid when lining up forms to be bolted together. Manufactured with a special thread design to insure easy threading of nut on bolt. Available in 5/8" x 2" or 3/4" x 2" length.



Panel Lock Tie

The Panel Lock Tie is used in conjunction with a Steel Wedge to quickly and securely lock adjacent form panel 2x4 studs together. The standard length is 3-1/2" with other lengths available on special request.



Coil Handle Nut

The Handle Coil Nut is fabricated by welding a substantial wire loop to a Standard Coil Nut. The unit is designed to provide quick tightening and release functions without the need of a wrench. Safe working load is based on approximate 2:1 safety factor.

| Coil Rod Diameter | Safe Working Load |
|-------------------|-------------------|
| 1/2" | 4,500 lbs |
| 3/4" | 9,000 lbs |
| 1" | 18,000 lbs |
| 1-1/4" | 27,000 lbs |



Steel Stakes

Steel Stakes are fabricated from quality steel round bar. They are available in 3/4" and 7/8" diameters with or without nail holes, in the standard lengths of 18", 24", 30", 36", 42" and 48"



J4F Hand Taps

Hand taps are available for chasing the coil threads in wing nuts and threaded brackets. They are also available for chasing the UNC or Coil inner threads of shebolts.



Plastic Coil Setting Plug

The Plastic Coil Setting Plugs are available in 1/2", 3/4" and 1" diameters. They are effectively used to set inserts in the form by nailing the plug to the form face and then threading the coil insert onto the plug. The reusable plugs are easily removed from the concrete after the form has been stripped. The Coil Setting Plug can also be used as a temporary cap when another pour will be made at a later time.

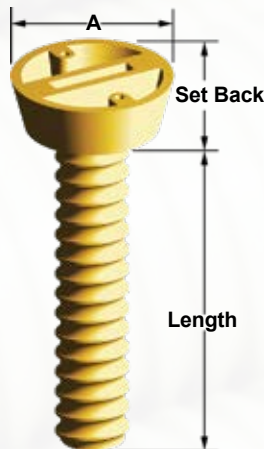

| Diameter | Set Back | Length | A |
|-----------------|-----------------|--------------------|-------------------|
| 1/2" (13 mm) | 1/2" (13 mm) | 2" (51 mm) | 1" (25 mm) |
| 3/4" (19 mm) | 3/4" (19 mm) | 3-1/4" (83 mm) | 1-1/2" (38 mm) |
| 1" (25 mm) | 3/4" (19 mm) | 4-3/4" (121 mm) | 1-3/4" (44 mm) |

Plastic NC Thread Plug



J1P Plastic Plugs

Plastic form plugs save money by increasing the life of expensive form panels. Relocate ties and plug old holes in wood or steel panels.



| Number | 9 | 10 | 12 | 13 | 15 | 17 | 18 | 19 |
|-----------|-------------------|--------------------|--------------------|--------------------|---------------------|---------------------|---------------------|--------------------|
| Hole Size | 9/16" (14 mm) | 5/8" (16 mm) | 3/4" (19 mm) | 13/16" (21 mm) | 15/16" (24 mm) | 1-1/16" (27 mm) | 1-1/8" (29 mm) | 1-3/16" (30 mm) |
| Number | 20 | 21 | 23 | 25 | 27 | 29 | 31 | 33 |
| Hole Size | 1-1/4" (32 mm) | 1-5/16" (33 mm) | 1-7/16" (37 mm) | 1-9/16" (40 mm) | 1-11/16" (43 mm) | 1-13/16" (46 mm) | 1-15/16" (49 mm) | 2-1/16" (52 mm) |

Tie Hole Plugs

Tie Hole Plugs are plastic plugs available in 9/16" and 13/16" diameters used to temporarily fill holes in the formwork plywood.





Accessories

Form Clamp System

Form Clamp - The Form Clamp is designed for use with the Pencil Rod or other similar mild steel bar. The clamp is available in three sizes to accept 1/4", 3/8" and 1/2" diameters. The Form Clamp is especially useful when unusual forming conditions exist, such as battered walls or walls of varying thickness. The safe working load of the Form Clamp is dependent on the setscrew being properly tightened and the pencil rod being bent 90 degrees at the back of the clamp. Safe working load is based on an approximate 2:1 safety factor.

| No. | Wire Size | SWL |
|-----|-----------|-----------|
| 1 | 1/4" | 1,125 lbs |
| 2 | 3/8" | 2,250 lbs |
| 3 | 1/2" | 3,750 lbs |

Pencil Rod - available in 1/4" diameter cut to 10', 20' or other specified length or in coils of approximately 600 feet (100 lbs) 3/8" and 1/2" Pencil Rod are also available on special order.

Pencil Rod Tightener - Tused in conjunction with the pencil rod/form clamp assembly to draw the formwork into position and hold it securely while the rod clamp set screw is tightened. The Tightener is available in 1/4", 3/8" and 1/2" diameters to match the pencil rod diameter being used.

Plastic Tubing - available for use when pencil rod must be removed from set concrete. The tubing is cut to size and slipped over the pencil rod to act as a sleeve to aid in the rod removal process. Plastic Tubing is stocked in 1/4", 3/8", 1/2", 3/4" and 1" diameters in 5' lengths.

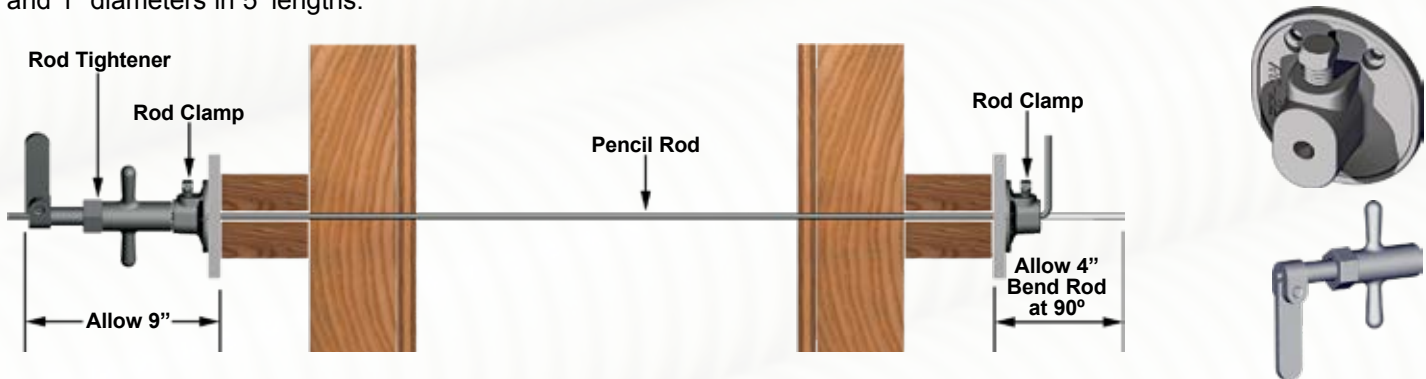

Bearing Plates

Williams steel bearing plates are available with round, dished or key holes. Bearing plates are customized for each application. Plate dimensions should be specified around the parameters of the project.

S1K - Round

R80 - Dished

S1K - Keyhole



Eye Nuts

Williams Eye Nuts may be used as lifting eyes for forms, concrete blocks, concrete cylinders, machinery or equipment. The large base on three of the models makes them excellent for anchoring guy wires. Safety factors and working loads based on the ultimate strength of the Eye Nuts should be determined for the specific application by the project design engineer.

NEB 200

E1N

E1N3

E1N4



| Eye Nut Designation | Minimum Inside Width | Inside Height | Ring Diameter | Overall Height | Taps Available | | | SWL (3:1 FS)** | SWL (5:1 FS)** | Blank Part Number |
|----------------------|----------------------|-----------------|-----------------|------------------|--------------------------------|-------------------|--------------------------------|----------------|---------------------------------------|-------------------|
| | | | | | UNC & Coil Tie Rods | Grade 60 Grade 75 | 150 KSI All-Thread | | | |
| NEB 50 Ductile Iron | 3" (76 mm) | 3" (76 mm) | 1" (25 mm) | 5-3/4" (146 mm) | 1/2" to 3/4" (13 to 19 mm) | #4 to #6 | | N/A | 5.2 kips (23 kN) | E1M-00-050 |
| NEB 75R Ductile Iron | 4" (102 mm) | 5" (127 mm) | 1" (25 mm) | 7-3/4" (197 mm) | 1/2" to 3/4" (13 to 19 mm) | #4 to #6 | | N/A | 4.6 kips (20 kN) | E1M-00-75R |
| NEB 100 Ductile Iron | 4" (102 mm) | 4-1/2" (114 mm) | 1-1/4" (32 mm) | 8" (203 mm) | 1" to 1-3/8" (25 to 36 mm) | #7 to #11 | 1" (25 mm) | 32 mm | 13 kips (58 kN) | E1M-00-100 |
| NEB 200 Ductile Iron | 5" (127 mm) | 6" (152 mm) | 2" (51 mm) | 11" (274 mm) | 1-3/8" to 2" (36 to 52 mm) | #11 to #14 | 1-1/4" to 1-3/4" (32 to 46 mm) | 38 mm 51 mm | 30 kips (133 kN) | E1M-00-200 |
| E1N * Cast Steel | 1-1/2" (38 mm) | 2-1/2" (64 mm) | 7/8" (22 mm) | 5-1/8" (130 mm) | 1/2" to 1" (13 to 25 mm) | #4 to #8 | - | - | 23 kips (104 kN) 14 kips (62 kN) | E1M-00-E1N |
| E1N3 Forged Steel | 2" (51 mm) | 3" (76 mm) | 1-3/4" (45 mm) | 8" (203 mm) | 1-1/8" to 1-3/8" (29 to 35 mm) | #10 to #11 | 1" to 1-3/8" (26 to 36 mm) | 38 mm | 87 kips (386 kN) 52 kips (231 kN) | E1M-00-E1N3 |
| E1N4 Forged Steel | 2-1/2" (64 mm) | 3-3/4" (95 mm) | 2-3/16" (56 mm) | 10" (254 mm) | 1-3/4" to 2" (45 to 51 mm) | #14 to #18 | 1-3/4" (46 mm) | 51 mm | 137 kips (608 kN) 82 kips (365 kN) | E1M-00-E1N4 |
| E1N4C Forged Steel | 3" (76 mm) | 5-3/4" (146 mm) | 2" (51 mm) | 11-1/2" (292 mm) | 1-1/4" to 2" (32 to 51 mm) | #10 to #18 | 1-3/8" to 1-3/4" (36 to 46 mm) | 51 mm | 124 kips (550 kN) 74 kips (330 kN) | E1M-00-E1N4C |

* Non-Domestic

** SWL based on straight tension loading only. Angled loading should be considered with caution, as it will significantly reduce Eyenut capacity. Contact your Williams representative for more information.



High Tensile Rods



UNC Threaded Tie Rods

ASTM A108 Grade C1045

| Bar Diameter & Pitch | Minimum Net Area Thru Threads | Minimum Ultimate Strength | Minimum Yield Strength | Part Number |
|----------------------|---|---------------------------|------------------------|-------------|
| 3/8" - 16 (9.5 mm) | 0.078 in ² (50.0 mm ²) | 9.30 kips (41.4 kN) | 7.13 kips (31.7 kN) | B8S-03 |
| 1/2" - 13 (13 mm) | 0.142 in ² (91.6 mm ²) | 17.0 kips (75.7 kN) | 13.1 kips (58.0 kN) | B8S-04 |
| 5/8" - 11 (16 mm) | 0.226 in ² (146 mm ²) | 27.1 kips (121 kN) | 20.8 kips (92.5 kN) | B8S-05 |
| 3/4" - 10 (19 mm) | 0.334 in ² (216 mm ²) | 40.0 kips (178 kN) | 30.7 kips (137 kN) | B8S-06 |
| 7/8" - 9 (22 mm) | 0.462 in ² (298 mm ²) | 55.4 kips (247 kN) | 42.5 kips (189 kN) | B8S-07 |
| 1" - 8 (25 mm) | 0.606 in ² (391 mm ²) | 72.7 kips (324 kN) | 55.8 kips (248 kN) | B8S-08 |
| 1-1/8" - 7 (28 mm) | 0.763 in ² (492 mm ²) | 80.1 kips (356 kN) | 61.8 kips (275 kN) | B8S-09 |
| 1-1/4" - 7 (32 mm) | 0.969 in ² (625 mm ²) | 102 kips (453 kN) | 78.5 kips (349 kN) | B8S-10 |
| 1-3/8" (35 mm) | 1.23 in ² (794 mm ²) | 129 kips (575 kN) | 99.6 kips (443 kN) | B8S-11 |
| 1-1/2" - 6 (38 mm) | 1.41 in ² (906 mm ²) | 148 kips (656 kN) | 114 kips (506 kN) | B8S-12 |
| 1-3/4" (45 mm) | 1.90 in ² (1226 mm ²) | 200 kips (887 kN) | 154 kips (685 kN) | B8S-14 |
| 2" - 6 (51 mm) | 2.65 in ² (1710 mm ²) | 278 kips (1238 kN) | 215 kips (955 kN) | B8S-16 |



Coil Threaded Tie Rods

ASTM A108 Grade C1045

| Bar Diameter & Pitch | Minimum Net Area Thru Threads | Minimum Ultimate Strength | Minimum Yield Strength | Part Number |
|------------------------|---|---------------------------|------------------------|-------------|
| 3/8" - 8 (9.5 mm) | 0.078 in ² (50.0 mm ²) | 9.30 kips (41.4 kN) | 7.13 kips (31.7 kN) | B7S-03 |
| 1/2" - 6 (13 mm) | 0.141 in ² (90.9 mm ²) | 16.9 kips (75.2 kN) | 13.0 kips (57.7 kN) | B7S-04 |
| 5/8" - 4-1/2 (16 mm) | 0.221 in ² (143 mm ²) | 26.5 kips (118 kN) | 20.3 kips (90.4 kN) | B7S-05 |
| 3/4" - 4-1/2 (19 mm) | 0.333 in ² (215 mm ²) | 40.0 kips (178 kN) | 30.6 kips (136 kN) | B7S-06 |
| 7/8" - 4-1/2 (22 mm) | 0.458 in ² (296 mm ²) | 55.0 kips (245 kN) | 42.1 kips (187 kN) | B7S-07 |
| 1" - 3-1/2 (25 mm) | 0.590 in ² (381 mm ²) | 70.8 kips (315 kN) | 54.3 kips (241 kN) | B7S-08 |
| 1-1/8" - 3-1/2 (28 mm) | 0.739 in ² (477 mm ²) | 77.6 kips (345 kN) | 59.9 kips (266 kN) | B7S-09 |
| 1-1/4" - 3-1/2 (32 mm) | 0.969 in ² (625 mm ²) | 102 kips (453 kN) | 78.5 kips (349 kN) | B7S-10 |
| 1-1/2" - 3-1/2 (38 mm) | 1.47 in ² (951 mm ²) | 155 kips (689 kN) | 119 kips (531 kN) | B7S-12 |

The following Hardened Washers and Beveled Washers are for use with Williams R6J Grade 60 Rebar as well as Williams High Tensile Coil & UNC Threaded Tie Rods.



R9F Hardened Washers

ASTM F436

| Bar Diameter | Outside Diameter | Inside Diameter | Thickness | Part Number |
|----------------|------------------|-----------------|----------------|-------------|
| 3/8" (9.5 mm) | 1" (25 mm) | 7/16" (11 mm) | 5/64" (2 mm) | R9F-03-436 |
| 1/2" (13 mm) | 1-1/16" (27 mm) | 9/16" (14 mm) | 9/64" (3.6 mm) | R9F-04-436 |
| 5/8" (16 mm) | 1-5/16" (33 mm) | 11/16" (17 mm) | 9/64" (3.6 mm) | R9F-05-436 |
| 3/4" (19 mm) | 1-7/16" (37 mm) | 13/16" (21 mm) | 9/64" (3.6 mm) | R9F-06-436 |
| 7/8" (22 mm) | 1-3/4" (45 mm) | 15/16" (24 mm) | 5/32" (4 mm) | R9F-07-436 |
| 1" (25 mm) | 2" (51 mm) | 1-1/16" (29 mm) | 5/32" (4 mm) | R9F-08-436 |
| 1-1/8" (29 mm) | 2-1/4" (57 mm) | 1-3/16" (30 mm) | 5/32" (4 mm) | R9F-09-436 |
| 1-1/4" (32 mm) | 2-1/2" (64 mm) | 1-3/8" (35 mm) | 5/32" (4 mm) | R9F-10-436 |
| 1-3/8" (36 mm) | 2-3/4" (70 mm) | 1-1/2" (38 mm) | 5/32" (4 mm) | R9F-11-436 |
| 1-1/2" (38 mm) | 3" (76 mm) | 1-5/8" (41 mm) | 5/32" (4 mm) | R9F-12-436 |
| 1-3/4" (43 mm) | 3-3/8" (86 mm) | 1-7/8" (48 mm) | 7/32" (6 mm) | R9F-14-436 |
| 2" (51 mm) | 3-3/4" (95 mm) | 2-1/8" (54 mm) | 7/32" (6 mm) | R9F-16-436 |
| 2-1/4" (57 mm) | 4" (102 mm) | 2-3/8" (60 mm) | 9/32" (7 mm) | R9F-18-436 |



R8M Beveled Washers

| Bar Diameter | Degree of Bevel | Outside Diameter | Inside Diameter | Maximum Thickness | Minimum Thickness | Part Number |
|----------------|-----------------|------------------|-----------------|-------------------|-------------------|-------------|
| 3/8" (9.5 mm) | 14° | 1-1/4" (32 mm) | 9/16" (14 mm) | 7/16" (11 mm) | 1/8" (3 mm) | R8M-03 |
| 1/2" (13 mm) | 14° | 1-1/4" (32 mm) | 9/16" (14 mm) | 7/16" (11 mm) | 1/8" (3 mm) | R8M-04 |
| 5/8" (16 mm) | 11° | 1-9/16" (40 mm) | 13/16" (21 mm) | 1/2" (13 mm) | 3/16" (5 mm) | R8M-06 |
| 3/4" (19 mm) | 11° | 1-9/16" (40 mm) | 13/16" (21 mm) | 1/2" (13 mm) | 3/16" (5 mm) | R8M-06 |
| 7/8" (22 mm) | 15° | 2-1/16" (52 mm) | 1" (25 mm) | 3/4" (19 mm) | 1/4" (6 mm) | R8M-08S |
| 1" (25 mm) | 15° | 2-1/16" (52 mm) | 1" (25 mm) | 3/4" (19 mm) | 1/4" (6 mm) | R8M-08S |
| 1-1/8" (29 mm) | 15° | 2-13/16" (71 mm) | 1-5/16" (33 mm) | 1" (25 mm) | 5/16" (8 mm) | R8M-09S |
| 1-1/4" (32 mm) | 15° | 3-3/8" (86 mm) | 1-9/16" (40 mm) | 1-15/64" (31 mm) | 3/8" (10 mm) | R8M-12S |
| 1-3/8" (36 mm) | 15° | 3-3/8" (86 mm) | 1-9/16" (40 mm) | 1-15/64" (31 mm) | 3/8" (10 mm) | R8M-12S |
| 1-1/2" (38 mm) | 15° | 3-1/2" (89 mm) | 1-3/4" (45 mm) | 1-1/4" (32 mm) | 3/8" (10 mm) | R8M-13S |
| 1-3/4" (43 mm) | 5° | 3-9/16" (91 mm) | 2-1/16" (52 mm) | 13/16" (21 mm) | 1/2" (13 mm) | R8M-16 |
| 2" (51 mm) | 5° | 3-9/16" (91 mm) | 2-1/16" (52 mm) | 13/16" (21 mm) | 1/2" (13 mm) | R8M-16 |
| 2-1/4" (57 mm) | - | - | - | - | - | - |

To achieve full strength of the system, beveled washers must be used in conjunction with a hardened washer.



Hex Nuts & Couplings

The following Hex Nuts, Stop-Type Couplings and Flange Couplings are for use with Williams High Tensile Coil Threaded Tie Rods.



H1F-C Regular Coil Hex Nuts & B25 Heavy Duty Coil Hex Nuts

| Bar Diameter | Across Flats | Across Corners | H1F Regular | | B-25 Heavy Duty | |
|-------------------|---------------------|-------------------|---------------------|-------------|-------------------|-------------|
| | | | Thickness | Part Number | Thickness | Part Number |
| 3/8" (9.5 mm) | 11/16" (18 mm) | 0.794" (20 mm) | 23/64" (9.1 mm) | H1F-03C | 3/4" (19 mm) | B25-03 |
| 1/2" (13 mm) | 7/8" (22 mm) | 1.01" (26 mm) | 31/64" (12 mm) | H1F-04C | 1" (25 mm) | B25-04 |
| 5/8" (16 mm) | 1-1/16" (27 mm) | 1.23" (31 mm) | 39/64" (16 mm) | H1F-05C | 1-1/4" (32 mm) | B25-05 |
| 3/4" (19 mm) | 1-1/4" (32 mm) | 1.44" (37 mm) | 47/64" (19 mm) | H1F-06C | 1-1/2" (38 mm) | B25-06 |
| 7/8" (22 mm) | 1-7/16" (37 mm) | 1.66" (42 mm) | 55/64" (22 mm) | H1F-07C | 1-3/4" (45 mm) | B25-07 |
| 1" (25 mm) | 1-5/8" (41 mm) | 1.88" (48 mm) | 63/64" (25 mm) | H1F-08C | 2" (51 mm) | B25-08 |
| 1-1/8" (28 mm) | 1-13/16" (46 mm) | 2.09" (53 mm) | 1-7/64" (28 mm) | H1F-09C | 2-1/4" (57 mm) | B25-09 |
| 1-1/4" (32 mm) | 2" (51 mm) | 2.31" (59 mm) | 1-7/32" (31 mm) | H1F-10C | 2-1/2" (64 mm) | B25-10 |
| 1-1/2" (38 mm) | 2-3/8" (60 mm) | 2.74" (70 mm) | 1-15/32" (37 mm) | H1F-12C | 3" (76 mm) | B25-12 |

C2T-C Stop-Type Coil Couplings & C2D-C Flange Coil Couplings

| Bar Diameter | Outside Diameter | Overall Length | Stop-Type Part No. | Flange Coupling | |
|-------------------|-------------------|--------------------|--------------------|--------------------------|----------|
| | | | | Flange Size | Part No. |
| 3/8" (9.5 mm) | 3/4" (19 mm) | 1-1/2" (38 mm) | C2T-03C | 2" x 2" (501 x 51 mm) | C2D-03C |
| 1/2" (13 mm) | 3/4" (19 mm) | 2" (51 mm) | C2T-04C | 2" x 2" (51 x 51 mm) | C2D-04C |
| 5/8" (16 mm) | 1" (25 mm) | 2-1/2" (64 mm) | C2T-05C | 2" x 2" (51 x 51 mm) | C2D-05C |
| 3/4" (19 mm) | 1-1/8" (29 mm) | 3" (76 mm) | C2T-06C | 2" x 2" (51 x 51 mm) | C2D-06C |
| 7/8" (22 mm) | 1-1/4" (32 mm) | 3-1/2" (89 mm) | C2T-07C | 3" x 3" (76 x 76 mm) | C2D-07C |
| 1" (25 mm) | 1-1/2" (38 mm) | 4" (102 mm) | C2T-08C | 3" x 3" (76 x 76 mm) | C2D-08C |
| 1-1/8" (28 mm) | 1-5/8" (41 mm) | 4-1/2" (114 mm) | C2T-09C | 3" x 3" (76 x 76 mm) | C2D-09C |
| 1-1/4" (32 mm) | 1-7/8" (48 mm) | 5" (127 mm) | C2T-10C | 3" x 3" (76 x 76 mm) | C2D-10C |
| 1-1/2" (38 mm) | 2-1/4" (57 mm) | 6" (152 mm) | C2T-12C | 3" x 3" (76 x 76 mm) | C2D-12C |

The following Hex Nuts, Stop-Type Couplings and Flange Couplings are for use with Williams R6J Grade 60 Rebar as well as Williams High Tensile UNC Threaded Tie Rods.



H1F Heavy Duty UNC Hex Nuts

| Bar Diameter | Across Flats | Across Corners | Thickness | Part Number |
|-------------------|----------------------|------------------|---------------------|-------------|
| 3/8" (9.5 mm) | 11/16" (18 mm) | 0.79" (20 mm) | 23/64" (9 mm) | H1F-03 |
| 1/2" (13 mm) | 7/8" (22 mm) | 1.0" (26 mm) | 31/64" (12 mm) | H1F-04 |
| 5/8" (16 mm) | 1-1/16" (27 mm) | 1.2" (31 mm) | 39/64" (16 mm) | H1F-05 |
| 3/4" (19 mm) | 1-1/4" (32 mm) | 1.4" (37 mm) | 47/64" (19 mm) | H1F-06 |
| 7/8" (22 mm) | 1-7/16" (36.6 mm) | 1.7" (42 mm) | 55/64" (22 mm) | H1F-07 |
| 1" (25 mm) | 1-5/8" (41 mm) | 1.9" (48 mm) | 63/64" (25 mm) | H1F-08 |
| 1-1/8" (29 mm) | 1-13/16" (46 mm) | 2.1" (53 mm) | 1-7/64" (28 mm) | H1F-09 |
| 1-1/4" (32 mm) | 2" (51 mm) | 2.3" (59 mm) | 1-7/32" (31 mm) | H1F-10 |
| 1-3/8" (36 mm) | 2-3/16" (56 mm) | 2.5" (64 mm) | 1-11/32" (34 mm) | H1F-11 |
| 1-1/2" (38 mm) | 2-3/8" (60 mm) | 2.7" (70 mm) | 1-15/32" (37 mm) | H1F-12 |
| 1-3/4" (43 mm) | 2-3/4" (70 mm) | 3.2" (81 mm) | 1-23/32" (44 mm) | H1F-14 |
| 2" (51 mm) | 3-1/8" (79 mm) | 3.6" (92 mm) | 1-31/32" (50 mm) | H1F-16 |
| 2-1/4" (57 mm) | 3-1/2" (89 mm) | 4.0" (103 mm) | 2-1/4" (57 mm) | H1F-18 |

C2T Stop-Type UNC Couplings & C2D Flange UNC Couplings

| Bar Diameter | Outside Diameter | Overall Length | Stop-Type Part Number | Flange Coupling | |
|-------------------|---------------------|--------------------|-----------------------|---------------------------|-------------|
| | | | | Flange Size | Part Number |
| 3/8" (9.5 mm) | 3/4" (19 mm) | 1-1/2" (38 mm) | C2T-03 | 2" x 2" (51 x 51 mm) | C2D-03 |
| 1/2" (13 mm) | 3/4" (19 mm) | 1-1/2" (38 mm) | C2T-04 | 2" x 2" (51 x 51 mm) | C2D-04 |
| 5/8" (16 mm) | 1" (25 mm) | 1-3/4" (45 mm) | C2T-05 | 2" x 2" (51 x 51 mm) | C2D-05 |
| 3/4" (19 mm) | 1-1/8" (29 mm) | 2" (51 mm) | C2T-06 | 2" x 2" (51 x 51 mm) | C2D-06 |
| 7/8" (22 mm) | 1-1/4" (32 mm) | 2-1/4" (57 mm) | C2T-07 | 3" x 3" (76 x 76 mm) | C2D-07 |
| 1" (25 mm) | 1-1/2" (38.1 mm) | 3" (76 mm) | C2T-08 | 3" x 3" (76 x 76 mm) | C2D-08 |
| 1-1/8" (29 mm) | 1-5/8" (41 mm) | 3-1/2" (89 mm) | C2T-09 | 3" x 3" (76 x 76 mm) | C2D-09 |
| 1-1/4" (32 mm) | 1-7/8" (48 mm) | 3-3/4" (95 mm) | C2T-10 | 3" x 3" (76 x 76 mm) | C2D-10 |
| 1-3/8" (35 mm) | 2-1/8" (54 mm) | 4" (102 mm) | C2T-11 | 3" x 3" (76 x 76 mm) | C2D-11 |
| 1-1/2" (38 mm) | 2-1/4" (57 mm) | 5" (127 mm) | C2T-12 | 3" x 3" (76 x 76 mm) | C2D-12 |
| 1-3/4" (45 mm) | 2-1/2" (64 mm) | 5-1/2" (140 mm) | C2T-14 | 4" x 4" (102 x 102 mm) | C2D-14 |
| 2" (51 mm) | 3" (76 mm) | 6" (152 mm) | C2T-16 | - | - |
| 2-1/4" (57 mm) | 3-1/2" (89 mm) | 8" (203 mm) | C2T-18 | - | - |



Reinforcing Bar

Grade 75 & Grade 80 All-Thread Rebar



Threads

Williams All-Thread Rebar has a cold rolled, continuous, rounded course thread form. Williams special thread (deformation) pattern projects ultra high relative rib area at 3 times that of conventional rebar. This provides for superior bond performance in concrete. Because of the high thread pitch and the full 360 degree concentric thread form, Williams All-Thread Rebar should only be bent under special provisions using larger bend diameters than typical ACI minimums. As an alternative to bending, Williams recommends use of a steel plate or a threaded terminator disc to reduce development length. Threads are available in both right and left hand. Grades up to 100 are available upon request.

Sizes

All-Thread Rebar is available in 12 diameters from #6 through #32. Diameters #6 to #24 are available in continuous lengths up to 50-foot, larger diameters up to 40-foot.

Welding

Welding of All-Thread Rebar should be approached with caution since no specific provisions have been included to enhance its weldability. Refer to ANSI/AWS D1.4 for proper selections and procedures.

R61 Grade 75 & Grade 80 All-Thread Rebar

ASTM A615*

| Bar Designation & Pitch | Minimum Net Area Thru Threads | Minimum Ultimate Strength | Grade 75 Minimum Yield Strength | Grade 80 Minimum Yield Strength | Nominal Weight | Approx. Thread Major Diameter | Part Number |
|-------------------------|---|---------------------------|---------------------------------|---------------------------------|-------------------------|-------------------------------|-------------|
| #6 - 5 (19 mm) | 0.44 in ² (284 mm ²) | 44 kips (196 kN) | 33 kips (147 kN) | 35 kips (156 kN) | 1.5 lbs/ft (2.4 kg/m) | 7/8" (22 mm) | R61-06 |
| #7 - 5 (22 mm) | 0.60 in ² (387 mm ²) | 60 kips (267 kN) | 45 kips (200 kN) | 48 kips (214 kN) | 2.0 lbs/ft (3.0 kg/m) | 1" (25 mm) | R61-07 |
| #8 - 3-1/2 (25 mm) | 0.79 in ² (510 mm ²) | 79 kips (351 kN) | 59 kips (264 kN) | 63 kips (280 kN) | 2.7 lbs/ft (3.9 kg/m) | 1-1/8" (29 mm) | R61-08 |
| #9 - 3-1/2 (29 mm) | 1.00 in ² (645 mm ²) | 100 kips (445 kN) | 75 kips (334 kN) | 80 kips (356 kN) | 3.4 lbs/ft (5.1 kg/m) | 1-1/4" (32 mm) | R61-09 |
| #10 - 3 (32 mm) | 1.27 in ² (819 mm ²) | 127 kips (565 kN) | 95 kips (424 kN) | 102 kips (454 kN) | 4.3 lbs/ft (5.5 kg/m) | 1-3/8" (35 mm) | R61-10 |
| #11 - 3 (36 mm) | 1.56 in ² (1006 mm ²) | 156 kips (694 kN) | 117 kips (521 kN) | 125 kips (556 kN) | 5.3 lbs/ft (7.9 kg/m) | 1-1/2" (38 mm) | R61-11 |
| #14 - 3 (43 mm) | 2.25 in ² (1452 mm ²) | 225 kips (1001 kN) | 169 kips (750 kN) | 180 kips (801 kN) | 7.65 lbs/ft (11.8 kg/m) | 1-7/8" (48 mm) | R61-14 |
| #18 - 3 (57 mm) | 4.00 in ² (2581 mm ²) | 400 kips (1780 kN) | 300 kips (1335 kN) | 320 kips (1423 kN) | 13.6 lbs/ft (19.6 kg/m) | 2-7/16" (62 mm) | R61-18 |
| #20 - 2-3/4 (64 mm) | 4.91 in ² (3168 mm ²) | 491 kips (2184 kN) | 368 kips (1637 kN) | 393 kips (1748 kN) | 16.7 lbs/ft (24.8 kg/m) | 2-3/4" (70 mm) | R61-20 |
| #24 - 2-3/4 (76 mm) * | 6.82 in ² (4400 mm ²) | 682 kips (3034 kN) | 512 kips (2277 kN) | 546 kips (2429 kN) | 24.0 lbs/ft (35.8 kg/m) | 3-3/16" (81 mm) | R61-24 |
| #28 - 2-3/4 (89 mm) * | 9.61 in ² (6200 mm ²) | 961 kips (4274 kN) | 720 kips (3206 kN) | 769 kips (3421 kN) | 32.7 lbs/ft (48.6 kg/m) | 3-3/4" (95 mm) | R61-28 |
| #32 - 2-3/4 (102 mm) * | 12.56 in ² (8103 mm ²) | 1256 kips (5587 kN) | 942 kips (4190 kN) | 1004 kips (4466 kN) | 43.0 lbs/ft (64.0 kg/m) | 4-1/4" (108 mm) | R61-32 |

* Bars size #24 and larger are not covered under ASTM A615. #32 Bar availability may be limited. Please contact Williams for specific lead times.

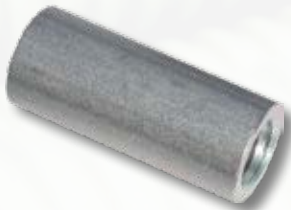

All Couplings and Hex/Collar Nuts exceed 100% of the bar's published ultimate strength and couplings will meet ACI 318 Section 25.5.7.1 for mechanical rebar connections.



Hex Nut



Round Collar Nut

R62 Stop-Type Couplings

| Bar Desig. & Nominal Dia. | Outside Diameter | Overall Length | Part Number |
|---------------------------|------------------|-----------------|-------------|
| #6 - 3/4" (19 mm) | 1-1/4" (32 mm) | 3-1/2" (89 mm) | R62-06 |
| #7 - 7/8" (22 mm) | 1-3/8" (35 mm) | 4" (102 mm) | R62-07 |
| #8 - 1" (25 mm) | 1-5/8" (41 mm) | 4-1/2" (114 mm) | R62-08 |
| #9 - 1-1/8" (29 mm) | 1-7/8" (48 mm) | 5" (127 mm) | R62-09 |
| #10 - 1-1/4" (32 mm) | 2" (51 mm) | 5-1/2" (140 mm) | R62-10 |
| #11 - 1-3/8" (36 mm) | 2-1/4" (57 mm) | 6" (152 mm) | R62-11 |
| #14 - 1-3/4" (43 mm) | 2-7/8" (73 mm) | 6" (152 mm) | R62-14 |
| #18 - 2-1/4" (57 mm) | 3-1/2" (89 mm) | 7-1/8" (181 mm) | R62-18 |
| #20 - 2-1/2" (64 mm) | 4" (102 mm) | 8" (203 mm) | R62-20 |
| #24 - 3" (76 mm) | 5" (127 mm) | 9-3/4" (248 mm) | R62-24 |
| #28 - 3-1/2" (89 mm) | 5-1/2" (140 mm) | 12" (305 mm) | R62-28 |
| #32 - 4" (102 mm) | 5-3/4" (146 mm) | 15" (381 mm) | R62-32 |

Couplings are available as tap thru upon request

R63 Hex Nuts & R 64 Collar Nuts

| Bar Desig. & Nominal Dia. | Across Flats | Across Corners | Thickness | Part Number |
|---------------------------|-----------------|-------------------|-----------------|-------------|
| #6 - 3/4" (19 mm) | 1-1/4" (32 mm) | 1.44" (37 mm) | 1-1/8" (29 mm) | R63-06 |
| #7 - 7/8" (22 mm) | 1-7/16" (37 mm) | 1.66" (42 mm) | 1-1/4" (32 mm) | R63-07 |
| #8 - 1" (25 mm) | 1-5/8" (41 mm) | 1.88" (48 mm) | 1-3/8" (35 mm) | R63-08 |
| #9 - 1-1/8" (29 mm) | 1-7/8" (48 mm) | 2.17" (55 mm) | 1-1/2" (38 mm) | R63-09 |
| #10 - 1-1/4" (32 mm) | 2" (51 mm) | 2.31" (59 mm) | 2" (51 mm) | R63-10 |
| #11 - 1-3/8" (36 mm) | 2-1/4" (57 mm) | 2.60" (66 mm) | 2-1/8" (54 mm) | R63-11 |
| #14 - 1-3/4" (43 mm) | 2-3/4" (70 mm) | 3.18" (81 mm) | 3" (76 mm) | R63-14 |
| #18 - 2-1/4" (57 mm) | 3-3/4" (95 mm) | 4.33" (110 mm) | 3-3/4" (95 mm) | R63-18 |
| #20 - 2-1/2" (64 mm) | 4" (102 mm) | 4.62" (117 mm) | 3-3/4" (95 mm) | R63-20 |
| #24 - 3" (76 mm) * | 4-1/2" (114 mm) | OD 5" (127 mm) | 4-3/8" (111 mm) | R64-24 |
| #28 - 3-1/2" (89 mm) * | 5-1/2" (140 mm) | OD 6" (152 mm) | 5-1/2" (140 mm) | R64-28 |
| #32 - 4" (102 mm) * | 5-3/4" (146 mm) | OD 6.25" (159 mm) | 7" (178 mm) | R64-32 |

* Round Collar Nut



Grade 75 & Grade 80 All-Thread Rebar



R81 Spherical Washers

| Bar Desig. & Nominal Dia. | Thickness | Outside Dome | Part Number |
|---------------------------|------------------|-----------------|-------------|
| #6 - 3/4" (19 mm) | 35/64" (14 mm) | 2" (51 mm) | R81-0675 |
| #7 - 7/8" (22 mm) | 39/64" (15 mm) | 2-1/4" (57 mm) | R81-0775 |
| #8 - 1" (25 mm) | 5/8" (16 mm) | 2-1/2" (64 mm) | R81-0875 |
| #9 - 1-1/8" (29 mm) | 3/4" (19 mm) | 2-3/4" (70 mm) | R81-0975 |
| #10 - 1-1/4" (32 mm) | 53/64" (21 mm) | 3" (76 mm) | R81-1075 |
| #11 - 1-3/8" (36 mm) | 29/32" (23 mm) | 3-1/4" (83 mm) | R81-1175 |
| #14 - 1-3/4" (43 mm) | 1-7/64" (28 mm) | 3-3/4" (95 mm) | R81-1475 |
| #18 - 2-1/4" (57 mm) | 1-13/32" (36 mm) | 5" (127 mm) | R81-1875 |
| #20 - 2-1/2" (64 mm) | 1-1/2" (38 mm) | 5-1/4" (133 mm) | R81-2075 |
| #24 - 3" (76 mm) | 1-7/8" (48 mm) | 6-1/2" (165 mm) | R81-2475 |
| #28 - 3-1/2" (89 mm) | 1-1/2" (38 mm) | 7" (178 mm) | R81-2875 |
| #32 - 4" (102 mm) | - | - | - |

Provides up to 5° angle when used with a dished plate.

R9F Hardened Washers

| Bar Desig. & Nominal Dia. | Outside Diameter | Inside Diameter | Thickness | Part Number |
|---------------------------|------------------|-----------------|--------------|-------------|
| #6 - 3/4" (19 mm) | 1-3/4" (44 mm) | 15/16" (24 mm) | 5/32" (4 mm) | R9F-07-436 |
| #7 - 7/8" (22 mm) | 2" (51 mm) | 1-1/16" (29 mm) | 5/32" (4 mm) | R9F-08-436 |
| #8 - 1" (25 mm) | 2-1/4" (57 mm) | 1-3/16" (30 mm) | 5/32" (4 mm) | R9F-09-436 |
| #9 - 1-1/8" (29 mm) | 2-1/4" (57 mm) | 1-3/16" (30 mm) | 5/32" (4 mm) | R9F-09-436 |
| #10 - 1-1/4" (32 mm) | 2-1/2" (64 mm) | 1-3/8" (35 mm) | 5/32" (4 mm) | R9F-10-436 |
| #11 - 1-3/8" (36 mm) | 3" (76 mm) | 1-5/8" (41 mm) | 5/32" (4 mm) | R9F-12-436 |
| #14 - 1-3/4" (43 mm) | 3-3/8" (86 mm) | 1-7/8" (48 mm) | 7/32" (6 mm) | R9F-14-436 |
| #18 - 2-1/4" (57 mm) | 4-1/2" (114 mm) | 2-5/8" (67 mm) | 9/32" (7 mm) | R9F-20-436 |
| #20 - 2-1/2" (64 mm) | 5" (127 mm) | 2-7/8" (73 mm) | 9/32" (7 mm) | R9F-22-436 |
| #24 - 3" (76 mm) | 6" (142 mm) | 3-3/8" (86 mm) | 9/32" (7 mm) | R9F-26-436 |
| #28 - 3-1/2" (89 mm) | 7" (178 mm) | 3-7/8" (98 mm) | 9/32" (7 mm) | R9F-30-436 |
| #32 - 4" (102 mm) | 7-3/4" (197 mm) | 4-3/8" (111 mm) | 5/16" (8 mm) | R9F-34-436 |



Jam Nuts can not be substituted for full strength nuts. Larger diameters will be a rounded collar jam nut, with special order machined hex available.



R63/R64-JN Jam Nuts

| Bar Desig. & Nominal Dia. | Across Flats | OD/Across Corners | Thickness | Part Number |
|---------------------------|-----------------|-------------------|------------------|-------------|
| #6 - 3/4" (19 mm) | 1-1/4" (32 mm) | 1.44" (37 mm) | 9/16" (14 mm) | R63-06JN |
| #7 - 7/8" (22 mm) | 1-7/16" (37 mm) | 1.66" (42 mm) | 5/8" (16 mm) | R63-07JN |
| #8 - 1" (25 mm) | 1-5/8" (41 mm) | 1.88" (48 mm) | 11/16" (17 mm) | R63-08JN |
| #9 - 1-1/8" (29 mm) | 1-7/8" (48 mm) | 2.17" (55 mm) | 3/4" (19 mm) | R63-09JN |
| #10 - 1-1/4" (32 mm) | 2" (51 mm) | 2.31" (59 mm) | 15/16" (24 mm) | R63-10JN |
| #11 - 1-3/8" (36 mm) | 2-1/4" (57 mm) | 2.60" (66 mm) | 1" (25 mm) | R63-11JN |
| #14 - 1-3/4" (43 mm) * | 2-5/8" (67 mm) | OD 2.88" (73 mm) | 1-3/16" (30 mm) | R64-14JN |
| #18 - 2-1/4" (57 mm) * | 3-1/4" (83 mm) | OD 3.5" (89 mm) | 1-11/16" (43 mm) | R64-18JN |
| #20 - 2-1/2" (64 mm) * | 3-3/4" (95 mm) | OD 4" (102 mm) | 1-11/16" (43 mm) | R64-20JN |
| #24 - 3" (76 mm) * | 4-1/2" (114 mm) | OD 5" (127 mm) | 2" (51 mm) | R64-24JN |
| #28 - 3-1/2" (89 mm) * | 5" (127 mm) | OD 5.5" (140 mm) | 2-1/4" (57 mm) | R64-28JN |
| #32 - 4" (102 mm) * | 5-3/4" (146 mm) | OD 6.25" (159 mm) | 2-1/2" (64 mm) | R64-32JN |

*Round Collar Jam Nut

R8M Beveled Washers

| Bar Desig. & Nominal Dia. | Degree of Bevel | Outside Diameter | Inside Diameter | Maximum Thickness | Minimum Thickness | Part Number |
|---------------------------|-----------------|------------------|-----------------|-------------------|-------------------|-------------|
| #6 - 3/4" (19 mm) | 15° | 2-1/16" (52 mm) | 1" (25 mm) | 3/4" (19 mm) | 1/4" (6 mm) | R8M-08S |
| #7 - 7/8" (22 mm) | 15° | 2-1/16" (52 mm) | 1" (25 mm) | 3/4" (19 mm) | 1/4" (6 mm) | R8M-08S |
| #8 - 1" (25 mm) | 15° | 2-13/16" (71 mm) | 1-5/16" (33 mm) | 1" (25 mm) | 5/16" (8 mm) | R8M-09S |
| #9 - 1-1/8" (29 mm) | 15° | 2-13/16" (71 mm) | 1-5/16" (33 mm) | 1" (25 mm) | 5/16" (8 mm) | R8M-09S |
| #10 - 1-1/4" (32 mm) | 15° | 3-3/8" (86 mm) | 1-9/16" (40 mm) | 1-15/64" (44 mm) | 3/8" (10 mm) | R8M-12S |
| #11 - 1-3/8" (36 mm) | 15° | 3-1/2" (89 mm) | 1-3/4" (44 mm) | 1-1/4" (32 mm) | 3/8" (10 mm) | R8M-13S |
| #14 - 1-3/4" (43 mm) | 15° | 4-1/2" (114 mm) | 2-1/8" (54 mm) | 1-5/8" (41 mm) | 15/32" (12 mm) | R8M-14S |
| #18 - 2-1/4" (57 mm) | 15° | 5" (127 mm) | 3" (76 mm) | 1-5/8" (41 mm) | 19/64" (8 mm) | R8M-18 |
| #20 - 2-1/2" (64 mm) | 10° | 5-1/2" (140 mm) | 3" (76 mm) | 1-23/32" (44 mm) | 3/4" (19 mm) | R8M-20 |
| #24 - 3" (76 mm) | 10° | 7" (178 mm) | 3-5/8" (92 mm) | 2" (51 mm) | 3/4" (19 mm) | R8M-24 |
| #28 - 3-1/2" (89 mm) | 10° | 8" (203 mm) | 4-1/4" (108 mm) | 2-19/64" (58 mm) | 7/8" (22 mm) | R8M-28 |
| #32 - 4" (102 mm) | - | - | - | - | - | - |

To achieve full strength of the system, beveled washers must be used in conjunction with a hardened washer



Grade 60 Rebar

Conventional Grade 60 Rebar in cut to length straight sections or custom bent to the design specifications is available in the following sizes from our Lithia Springs, GA location. See tables on following page for typical ACI bend configurations.



R4J Grade 60 Rebar

ASTM 615

| Bar Designation | Nominal Diameter | Cross Sectional Area | Minimum Ultimate Strength | 1.25 x Yield ACI Capacity Requirement | Minimum Yield Strength | Nominal Weight | Part Number |
|-----------------|-------------------|--|---------------------------|---------------------------------------|------------------------|----------------------------|-------------|
| #4 | 1/2" (12 mm) | 0.20 in ² (129 mm ²) | 16 kips (71.2 kN) | 15 kips (66.8 kN) | 12 kips (53.4 kN) | 0.67 lbs/ft (0.99 kg/m) | R4J-04 |
| #5 | 5/8" (16 mm) | 0.31 in ² (200 mm ²) | 25.6 kips (114 kN) | 23.3 kips (103 kN) | 18.6 kips (82.7 kN) | 1.0 lbs/ft (1.6 kg/m) | R4J-05 |
| #6 | 3/4" (20 mm) | 0.44 in ² (284 mm ²) | 35.2 kips (157 kN) | 33.0 kips (147 kN) | 26.4 kips (117 kN) | 1.5 lbs/ft (2.2 kg/m) | R4J-06 |
| #7 | 7/8" (22 mm) | 0.60 in ² (387 mm ²) | 48.0 kips (214 kN) | 45.0 kips (200 kN) | 36.0 kips (160 kN) | 2.0 lbs/ft (3.0 kg/m) | R4J-07 |
| #8 | 1" (25 mm) | 0.79 in ² (510 mm ²) | 63.2 kips (281 kN) | 59.3 kips (264 kN) | 47.4 kips (211 kN) | 2.7 lbs/ft (4.0 kg/m) | R4J-08 |
| #9 | 1-1/8" (29 mm) | 1.00 in ² (645 mm ²) | 80.0 kips (356 kN) | 75.0 kips (334 kN) | 60.0 kips (267 kN) | 3.4 lbs/ft (5.1 kg/m) | R4J-09 |
| #10 | 1-1/4" (32 mm) | 1.27 in ² (819 mm ²) | 102 kips (454 kN) | 95.3 kips (424 kN) | 76.2 kips (339 kN) | 4.30 lbs/ft (6.4 kg/m) | R4J-10 |
| #11 | 1-3/8" (35 mm) | 1.56 in ² (1006 mm ²) | 125 kips (556 kN) | 117 kips (520 kN) | 93.6 kips (416 kN) | 5.3 lbs/ft (7.9 kg/m) | R4J-11 |
| #14 | 1-3/4" (45 mm) | 2.25 in ² (1,452 mm ²) | 180 kips (801 kN) | 169 kips (751 kN) | 135 kips (601 kN) | 7.7 lbs/ft (11.4 kg/m) | R4J-14 |
| #18 | 2-1/4" (57 mm) | 4.00 in ² (2,581 mm ²) | 320 kips (1423 kN) | 300 kips (1334 kN) | 240 kips (1068 kN) | 13.6 lbs/ft (20.2 kg/m) | R4J-18 |

Our R6J Grade 60 Rebar is available with a limited length (up to 12 diameters) of Unified National thread on one or both ends in straight or bent configurations. This allows the rebar to be used as fasteners in embedded dowels, for resin and grout bonded anchors, concrete joint splices or for simply joining long rebar lengths. Standard stock lengths of rebar up to 60' are available.



R6J Grade 60 Threaded End Rebar

ASTM 615

| Bar Designation Nominal Diameter & Pitch | Minimum Net Area Thru Threads | Minimum Ultimate Strength | Minimum Yield Strength | Nominal Weight | Approx. Thread Major Dia. | Part Number |
|--|--|---------------------------------|------------------------------|----------------------------|---------------------------------|----------------|
| #4 - 1/2" - 13 UNC (13 mm) | 0.142 in ² (91.6 mm ²) | 11.3 kips (50.5 kN) | 8.52 kips (37.9 kN) | 0.67 lbs/ft (1.0 kg/m) | 1/2" (13 mm) | R6J-04 |
| #5 - 5/8" - 11 UNC (16 mm) | 0.226 in ² (146 mm ²) | 18.1 kips (80.4 kN) | 13.6 kips (60.3 kN) | 1.0 lbs/ft (1.6 kg/m) | 5/8" (16 mm) | R6J-05 |
| #6 - 3/4" - 10 UNC (19 mm) | 0.334 in ² (216 mm ²) | 26.7 kips (119 kN) | 20.0 kips (89.1 kN) | 1.5 lbs/ft (2.2 kg/m) | 3/4" (19 mm) | R6J-06 |
| #7 - 7/8" - 9 UNC (22 mm) | 0.462 in ² (298 mm ²) | 37.0 kips (164 kN) | 27.7 kips (123 kN) | 2.0 lbs/ft (3.0 kg/m) | 7/8" (22 mm) | R6J-07 |
| #8 - 1" - 8 UNC (25 mm) | 0.606 in ² (391 mm ²) | 48.5 kips (216 kN) | 36.4 kips (162 kN) | 2.7 lbs/ft (4.0 kg/m) | 1" (25 mm) | R6J-08 |
| #9 - 1-1/8" - 7 UNC (29 mm) | 0.763 in ² (492 mm ²) | 61.0 kips (271 kN) | 45.8 kips (200 kN) | 3.4 lbs/ft (5.1 kg/m) | 1-1/8" (29 mm) | R6J-09 |
| #10 - 1-1/4" - 7 UNC (32 mm) | 0.969 in ² (625 mm ²) | 77.5 kips (345 kN) | 58.1 kips (259 kN) | 4.3 lbs/ft (6.4 kg/m) | 1-1/4" (32 mm) | R6J-10 |
| #11 - 1-3/8" - 8 UN (36 mm) | 1.23 in ² (794 mm ²) | 98.6 kips (439 kN) | 73.8 kips (328 kN) | 5.3 lbs/ft (7.9 kg/m) | 1-3/8" (34.9 mm) | R6J-11 |
| #14 - 1-3/4" - 5 UNC (43 mm) | 1.90 in ² (1226 mm ²) | 149 kips (663 kN) | 110 kips (489 kN) | 7.7 lbs/ft (11.4 kg/m) | 1-3/4" (45 mm) | R6J-14 |
| #18 - 2-1/4" - 4-1/2 UNC (57 mm) | 3.25 in ² (2097 mm ²) | 255 kips (1134 kN) | 189 kips (841 kN) | 13.6 lbs/ft (20.2 kg/m) | 2-1/4" (57 mm) | R6J-18 |

* The #14 and #18 diameters are made from 400W rebar from Canada.



Grade 60 All-Thread Rebar



R51 Grade 60 All-Thread-Rebar

ASTM 615

| Bar Designation & Nominal Diameter | Minimum Net Area Thru Threads | Minimum Ultimate Strength | Minimum Yield Strength | Nominal Weight | Approximate Thread Major Diameter | Part Number |
|------------------------------------|--|---------------------------|------------------------|---------------------------|-----------------------------------|-------------|
| #4 - 1/2" (13 mm) | 0.2 in ² (129 mm ²) | 16 kips (71.2 kN) | 12.0 kips (53.4 kN) | 0.68 lbs/ft (1.0 kg/m) | 5/8" (16 mm) | R51-04 |
| #5 - 5/8" (16 mm) | 0.32 in ² (206 mm ²) | 25.6 kips (114 kN) | 19.2 kips (85.4 kN) | 1.09 lbs/ft (1.6 kg/m) | 3/4" (19 mm) | R51-05 |
| #6 - 3/4" (19 mm) | 0.44 in ² (284 mm ²) | 35.2 kips (157 kN) | 26.4 kips (117 kN) | 1.5 lbs/ft (2.4 kg/m) | 7/8" (22 mm) | R51-06 |
| #7 - 7/8" (22 mm) | 0.60 in ² (387 mm ²) | 48.0 kips (214 kN) | 36.0 kips (160 kN) | 2.0 lbs/ft (3.0 kg/m) | 1" (25 mm) | R51-07 |
| #8 - 1" (25 mm) | 0.79 in ² (510 mm ²) | 63.2 kips (281 kN) | 47.4 kips (211 kN) | 2.7 lbs/ft (3.9 kg/m) | 1-1/8" (29 mm) | R51-08 |

Williams All-Thread Grade 60 Rebar is a continuously threaded bendable alternative to traditional rebar. All-Thread-Rebar can be spliced with a mechanical coupling which is capable of developing 100% of the bars tensile capacity.



R52 Stop-Type Couplings



R53 Hex Nuts



R9F Hardened Washers

| Bar Desig. & Nominal Dia. | Outside Diameter | Overall Length | Part Number |
|---------------------------|--------------------|-------------------|-------------|
| #4 - 1/2" (13 mm) | 15/16" (24 mm) | 2-1/8" (54 mm) | R52-04 |
| #5 - 5/8" (16 mm) | 1-1/16" (27 mm) | 2-3/8" (60 mm) | R52-05 |
| #6 - 3/4" (19 mm) | 1-1/4" (32 mm) | 2-3/4" (70 mm) | R52-06 |
| #7 - 7/8" (22 mm) | 1-3/8" (35 mm) | 3-1/4" (83 mm) | R52-07 |
| #8 - 1" (25 mm) | 1-5/8" (41 mm) | 3-7/8" (98 mm) | R52-08 |

| Across Flats | Across Corners | Thickness | Part Number |
|--------------------|------------------|-------------------|-------------|
| 15/16" (24 mm) | 1.08" (28 mm) | 5/8" (16 mm) | R53-04 |
| 1-1/16" (27 mm) | 1.23" (31 mm) | 3/4" (19 mm) | R53-05 |
| 1-1/4" (32 mm) | 1.44" (37 mm) | 7/8" (22 mm) | R53-06 |
| 1-7/16" (37 mm) | 1.66" (42 mm) | 1" (25 mm) | R53-07 |
| 1-5/8" (41 mm) | 1.88" (48 mm) | 1-1/8" (29 mm) | R53-08 |

| Outside Diameter | Inside Diameter | Thickness | Part Number |
|--------------------|--------------------|-------------------|-------------|
| 1-5/16" (33 mm) | 11/16" (18 mm) | 9/64" (3.6 mm) | R9F-05-436 |
| 1-7/16" (37 mm) | 13/16" (21 mm) | 9/64" (3.6 mm) | R9F-06-436 |
| 1-3/4" (45 mm) | 15/16" (24 mm) | 5/32" (4.0 mm) | R9F-07-436 |
| 2" (51 mm) | 1-1/16" (29 mm) | 5/32" (4.0 mm) | R9F-08-436 |
| 2-1/4" (57 mm) | 1-3/16" (30 mm) | 5/32" (4.0 mm) | R9F-09-436 |

System Advantages

The Williams All-thread Rebar Splice System allows you to field produce Rebar Dowel Connections from stock inventory. The ease of producing your own splices simplifies the forming operation and helps meet scheduling deadlines.

- No waiting for custom sizes or lengths
- Easy field assembly
- No special tools required
- Eliminates Protruding Dowels
- No torque requirements
- Stop type coupling insures proper engagement
- Reduces forming and stripping cost
- Full Strength Splice



C2DD Flange Couplings

System Compliance

The Grade 60 All-Thread Rebar Splice System complies with the following standards and specifications.

- IAPMO Evaluation Report # 0205
- American Concrete Institute (ACI Standard 318)
- 2009 International Building Code (IBC)
- 2009 International Residential Code (IRC)
- State Departments of Transportation.

| Bar Desig. & Nominal Dia. | Outside Diameter | Coupling Length | Flange Depth | Flange Width | Part Number |
|---------------------------|--------------------|-------------------|--------------------|---------------|-------------|
| #4 - 1/2" (13 mm) | 15/16" (24 mm) | 2-1/8" (54 mm) | 0.063" (1.6 mm) | 2" (51 mm) | C2DD-04 |
| #5 - 5/8" (16 mm) | 1-1/16" (27 mm) | 2-3/8" (60 mm) | 0.063" (1.6 mm) | 2" (51 mm) | C2DD-05 |
| #6 - 3/4" (19 mm) | 1-1/4" (32 mm) | 2-3/4" (70 mm) | 0.063" (1.6 mm) | 2" (51 mm) | C2DD-06 |
| #7 - 7/8" (22 mm) | 1-3/8" (35 mm) | 3-1/4" (83 mm) | 0.063" (1.6 mm) | 3" (76 mm) | C2DD-07 |
| #8 - 1" (25 mm) | 1-5/8" (41 mm) | 3-7/8" (98 mm) | 0.063" (1.6 mm) | 3" (76 mm) | C2DD-08 |



Rebar Connections

Williams has designed a safe, economical way of extending rebar without destroying the form face. By using a Rebar Flange Coupler, you can connect the rebar directly to the form, thus eliminating hazardous conditions caused by extended rebar.

C2D Rebar Flange Coupler

| Bar Designation | Bar Diameter | Outside Diameter | Overall Length | Flange Size | Minimum Yield | Average Ultimate | Part Number |
|-----------------|----------------|------------------|-----------------|------------------------|--------------------|-------------------|-------------|
| #4 | 1/2" (13 mm) | 3/4" (19 mm) | 1-1/2" (38 mm) | 2" x 2" (51 x 51 mm) | 8.5 kips (37.7 kN) | 13 kips (56 kN) | C2D-04 |
| #5 | 5/8" (16 mm) | 1" (25 mm) | 1-3/4" (45 mm) | 2" x 2" (51 x 51 mm) | 13 kips (57.7 kN) | 20 kips (90 kN) | C2D-05 |
| #6 | 3/4" (19 mm) | 1-1/8" (28 mm) | 2" (51 mm) | 2" x 2" (51 x 51 mm) | 20 kips (88.9 kN) | 30 kips (133 kN) | C2D-06 |
| #7 | 7/8" (22 mm) | 1-1/4" (32 mm) | 2-1/4" (57 mm) | 3" x 3" (76 x 76 mm) | 27 kips (120 kN) | 42 kips (184 kN) | C2D-07 |
| #8 | 1" (25 mm) | 1-1/2" (38 mm) | 3" (76 mm) | 3" x 3" (76 x 76 mm) | 36 kips (160 kN) | 55 kips (242 kN) | C2D-08 |
| #9 | 1-1/8" (29 mm) | 1-5/8" (41 mm) | 3-1/2" (89 mm) | 3" x 3" (76 x 76 mm) | 45 kips (200 kN) | 69 kips (305 kN) | C2D-09 |
| #10 | 1-1/4" (32 mm) | 1-7/8" (48 mm) | 3-3/4" (95 mm) | 3" x 3" (76 x 76 mm) | 58 kips (258 kN) | 87 kips (389 kN) | C2D-10 |
| #11 | 1-3/8" (35 mm) | 2-1/8" (54 mm) | 4" (102 mm) | 3" x 3" (76 x 76 mm) | 73 kips (325 kN) | 111 kips (493 kN) | C2D-11 |
| #14 | 1-3/4" (43 mm) | 2-1/2" (64 mm) | 5-1/2" (140 mm) | 4" x 4" (102 x 102 mm) | 114 kips (507 kN) | 171 kips (761 kN) | C2D-14 |



Advantages

- Enables coupler to attach to form individually or coupled to rebar
- Enables coupler to be removed from damaged rebar and re-used
- Eliminate large holes in form face for rebar to pass through
- Enables coupler to be installed with other types of embeds
- Enables coupler and rebar to be easily stored
- Eliminate stripping form over extended rebar
- Eliminate complicated bulkhead forms
- Eliminate personal injury

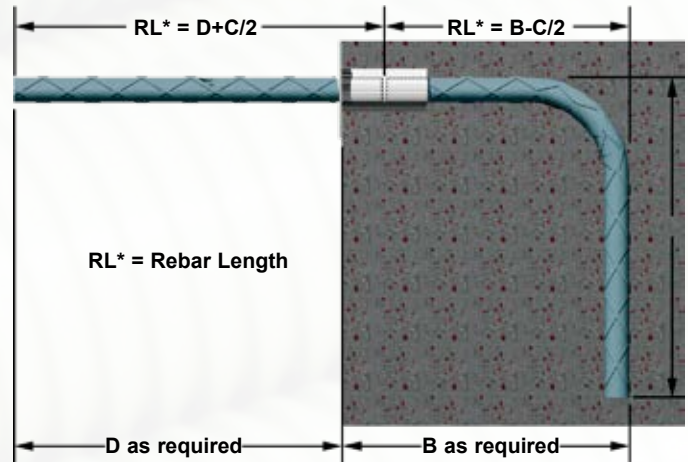
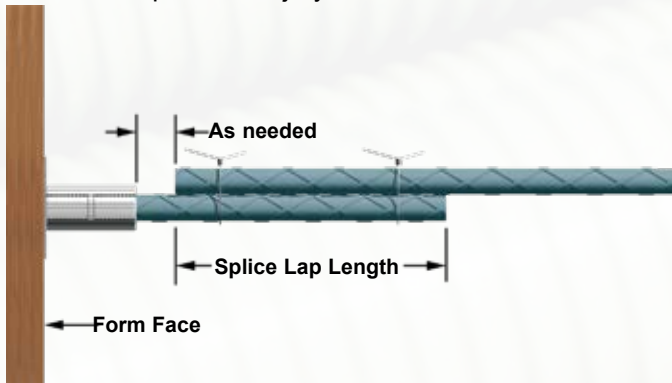

Rebar Tension Splice Lap Lengths

| Rebar Desg. | Top Bars | | | | | | Other Bars | | | | | |
|-------------|------------------|------------------|-------------------|-------------------|-------------------|-------------------|------------------|------------------|------------------|------------------|-------------------|------------------|
| | A | | B | | C | | A | | B | | C | |
| | Less than 6" | 6" or More | Less than 6" | 6" or More | Less than 6" | 6" or More | Less than 6" | 6" or More | Less than 6" | 6" or More | Less than 6" | 6" or More |
| #4 | 17" (432 mm) | 13" (330 mm) | 22" (559 mm) | 17" (432 mm) | 29" (767 mm) | 23" (584 mm) | 12" (305 mm) | 12" (305 mm) | 16" (406 mm) | 12" (305 mm) | 20" (508 mm) | 16" (406 mm) |
| #5 | 20" (508 mm) | 17" (432 mm) | 25" (635 mm) | 20" (508 mm) | 34" (864 mm) | 27" (686 mm) | 14" (356 mm) | 12" (305 mm) | 18" (457 mm) | 14" (356 mm) | 24" (610 mm) | 19" (483 mm) |
| #6 | 27" (686 mm) | 22" (559 mm) | 35" (889 mm) | 28" (711 mm) | 46" (1168 mm) | 37" (940 mm) | 19" (483 mm) | 15" (381 mm) | 25" (635 mm) | 20" (508 mm) | 32" (813 mm) | 26" (660 mm) |
| #7 | 37" (940 mm) | 29" (737 mm) | 48" (1219 mm) | 38" (965 mm) | 63" (1600 mm) | 50" (1270 mm) | 26" (660 mm) | 21" (533 mm) | 34" (864 mm) | 27" (686 mm) | 44" (1118 mm) | 36" (914 mm) |
| #8 | 48" (1219 mm) | 38" (965 mm) | 63" (1600 mm) | 49" (1245 mm) | 82" (2083 mm) | 65" (1651 mm) | 35" (889 mm) | 28" (711 mm) | 46" (1168 mm) | 36" (914 mm) | 60" (1524 mm) | 47" (1194 mm) |
| #9 | 61" (1549 mm) | 49" (1245 mm) | 80" (2032 mm) | 64" (1626 mm) | 104" (2642 mm) | 83" (2108 mm) | 44" (1118 mm) | 35" (889 mm) | 57" (1448 mm) | 46" (1168 mm) | 75" (1905 mm) | 60" (1524 mm) |
| #10 | 78" (1981 mm) | 62" (1575 mm) | 101" (2565 mm) | 81" (2057 mm) | 132" (3353 mm) | 105" (2667 mm) | 56" (1422 mm) | 45" (1143 mm) | 73" (1854 mm) | 58" (1473 mm) | 95" (2413 mm) | 76" (1930 mm) |
| #11 | 96" (2438 mm) | 77" (1956 mm) | 124" (3150 mm) | 100" (2540 mm) | 163" (4140 mm) | 131" (3327 mm) | 68" (1727 mm) | 55" (1397 mm) | 88" (2235 mm) | 71" (1803 mm) | 116" (2946 mm) | 93" (2362 mm) |

ASTM A-615, Grade 60 Reinforcing Steel Bars. Normal weight, 3,000 psi concrete. See ACI 318 Chapter 25 for lap splice classifications and exceptions.



Rebar Connections

Williams has considerable capabilities when it comes to couplings. Couplings can be tapped for UNC, Coil or Grade 75 in round or hex material, in any of the following four styles: Tap-Through, Stop-Type, Reducer or Reattachment.

Round Coupling



Hex Coupling



Tap-Thru Couplings

Williams standard tap-thru couplings meet or exceed the strengths of the related high tensile tie rods and may be turned completely on either rod.



Stop-Type Couplings

The Williams stop type coupling is designed to assure exact engagement on both rods, and meet or exceed the full tensile strength of the bar.



Reducer Couplings

Reducer Couplings are designed to couple a larger diameter bar to a smaller diameter bar.



Reattachment Couplings

A coupling adjusted to fit into the prior mold of a she-bolt. May be used to attach the rods to forms needed for second or third pour.

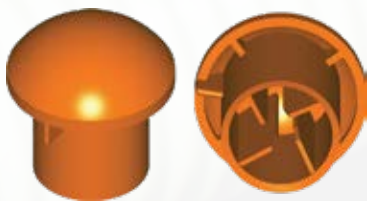

J6P Bar Cap

The Bar Cap is available in two sizes for the purpose of protection from scrapes, cuts and torn clothing caused by protruding rebar. It is not intended for use as an impalement protector. The small size accepts rebar sizes #3 through #8 and the larger size accepts rebar from #9 through #14.

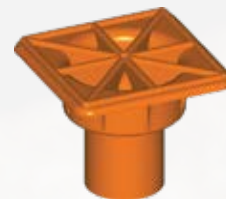

Rebar Safety Cap

The Rebar Safety Cap is an OSHA approved impalement protection safety cap. It is available in two sizes; the smaller size accepts rebar sizes #3 through #8 and the larger size will accommodate rebar sizes #7 through #12. the larger size accepts rebar from #9 though #14.



Rebar Connections

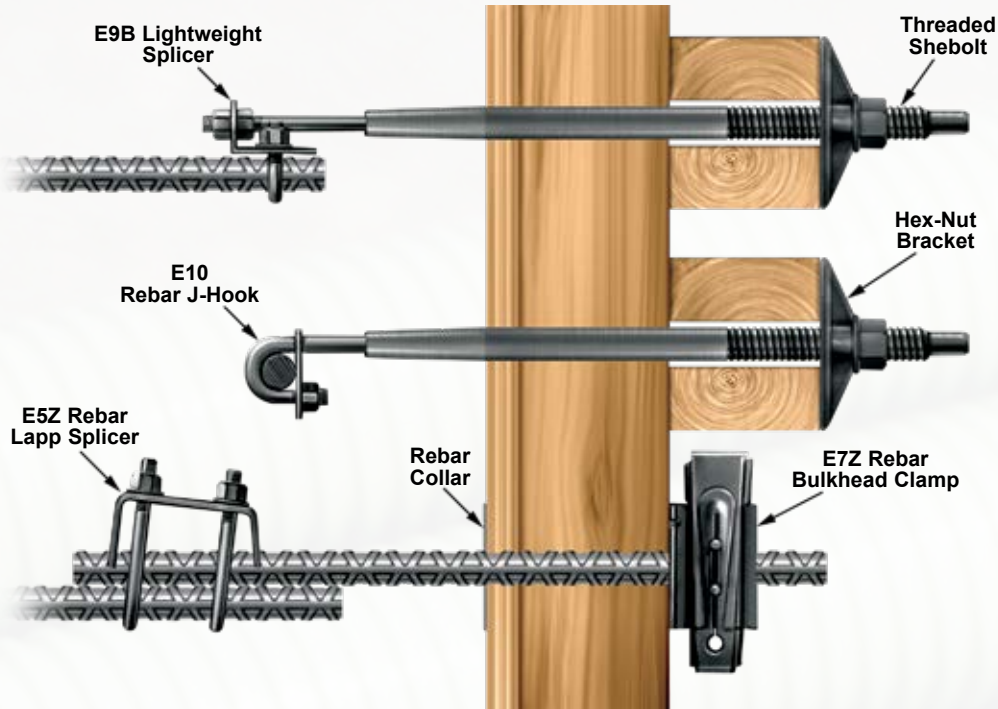

E9B Lightweight Splicer

Rebar-Tie Splicer for 3/8" Tie Rods

Designed to work with Williams 3/8" high tensile tie rods. Splicer develops a 4,900 lb. (21.8 kN) working load and 9,800 lb. (43.6 kN) ultimate strength. Standard sizes for #6 through #14 rebar. Recommended torque of U-bolt hex nuts is 40 ft. Lbs.

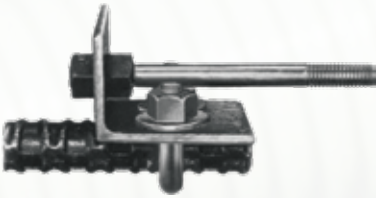

E10 Rebar J-Hook

Williams Rebar J-Hook is an approved method of anchoring to the rebar. Most popular uses include Nuclear Plants where welding to the rebar is not permitted and tying down battered wall forms to resist uplift. J-Hooks are available in 3/8" and 1/2" diameters for most popular rebar sizes.

State Rebar size (A) and J-Hook length (B) when ordering.



E6Z Rebar Tie Splicer

Single splicer develops the 9,000 lb. (40.0 kN) working load and 18,000 lb. (80.1 kN) ultimate of Williams 1/2" high tensile tie rod. Special design matches the angle of the serrations on the rebar for maximum strength. Recommended torque on U-bolt hex nuts is 40-ft. lbs. Available for #8 through #11 rebar.



E7Z Rebar Bulkhead Clamp

Rebar Bulkhead Clamps are designed for use on large or small bulkheads when the rebar must run continuous. The clamp uses Williams standard steel or malleable wedge for fast assembly and minimum material costs. Wedge clamp available up to #8 Rebar. Rebars of larger sizes use nuts and washers.



E5Z Rebar Lapp Splicer

Light duty splicer with continuous strength for difficult forming situations. Caution: This splicer is not a full strength rebar connection.



| Rebar | Recommended Torque on Hex Nuts | Working Load 2 to 1 SF | Average Ultimate Strength |
|---------------|--------------------------------|------------------------|---------------------------|
| #4; #5 | 15 ft-lbs | 3.8 kips (17 kN) | 7.5 kips (33 kN) |
| #6; #7 | 40 ft-lbs | 5 kips (22 kN) | 10 kips (44 kN) |
| #8; #9 #10 | 40 ft-lbs | 7.5 kips (33 kN) | 15 kips (67 kN) |
| #11 | 40 ft-lbs | 10 kips (45 kN) | 20 kips (89 kN) |



Plastic Rebar Supports

Slab Beam Bolster

The Slab Beam Bolster is fabricated from fiber-filled composite material. They are gray in color to blend with the concrete. The top bar corrugations are on 1" centers to aid rebar placement. It is available in 5' lengths and heights from 3/4" to 4" in 1/4" increments.



Intersectional Chair

The Intersectional Chair is designed for use at the intersection of two crossing lengths of post tensioning cables rebar to correctly position and firmly hold the two bars in place. The large support base gives added benefit when used on vapor barriers or soft fill. The chair is available in most heights from 1-1/2" to 7" in 1/2" increments.

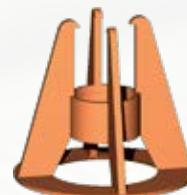

Mesh Chair with Base

The Mesh Chair with Base is a special high chair with sand plate for use on soft surfaces and/or slab on grade to correctly position and hold the wire mesh securely in place. Each size chair is designed to service two mesh positioning heights. It is available in heights from 5/8" to 4".



Snap-On Mesh Chair & Snap-On Mesh Chair with Base

The Snap-On Mesh Chairs are economically heavy duty, four sided chairs that quickly snap onto the mesh to correctly position it in the slab. The Snap-On Mesh Chair is available in most heights from 3/4" to 3" and the Snap-On Mesh Chair with Base is available in heights from 1-1/2" to 4".



Snap-On Paving Chair with Base & Snap-On Bar Chair

The Snap-On Paving Chair and the Snap-On Bar Chair are substantial plastic bar supports available to support reinforcing steel in various applications. The Snap-On Paving Chair is available in heights from 3/4" to 7" and the Snap-On Bar Chair is available in heights from 3/4" to 3".



Plastic Bar Chair

The Plastic Bar Chair is available in heights from 3/4" to 1-3/4" in 1/4" increments.



Plaswheel

The Plaswheel is designed to quickly snap onto and space vertical or horizontal steel at side walls and columns. They are available to accommodate #2 through #8 rebar and provide 5/8" through 4" concrete cover.



Unispacer

The Unispacer is an economical spacer available in one size to provide a 2" concrete cover. It slides onto any rebar up to #14 size and permits rotation and/or movement of the rebar without risk of the spacer coming off.





Rebar Bends

All specific sizes recommended meet minimum requirements of ACI 318. Taken from ACI *Manual of Concrete Practice*.

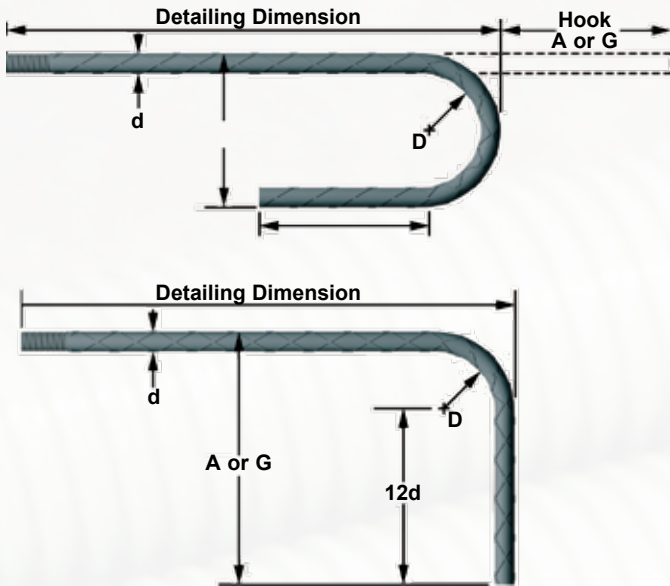

Recommended End Hooks

| Bar Size | D Finished Bend Diameter | 180° Hook | | 90° Hook |
|----------|--------------------------|-----------------|---------------------|------------------|
| | | A or G | J | A or G |
| #4 | 3" (76 mm) | 6" (152 mm) | 4" (102 mm) | 8" (203 mm) |
| #5 | 3-3/4" (95 mm) | 7" (178 mm) | 5" (127 mm) | 10" (254 mm) |
| #6 | 4-1/2" (114 mm) | 8" (203 mm) | 6" (152 mm) | 12" (305 mm) |
| #7 | 5-1/4" (133 mm) | 10" (254 mm) | 7" (178 mm) | 14" (356 mm) |
| #8 | 6" (152 mm) | 11" (279 mm) | 8" (203 mm) | 18" (457 mm) |
| #9 | 9-1/2" (241 mm) | 15" (381 mm) | 11-3/4" (298 mm) | 19" (483 mm) |
| #10 | 10-3/4" (273 mm) | 17" (432 mm) | 13-1/4" (337 mm) | 22" (559 mm) |
| #11 | 12" (305 mm) | 19" (483 mm) | 14-3/4" (375 mm) | 24" (610 mm) |
| #14 | 18-1/4" (464 mm) | 27" (686 mm) | 21-3/4" (552 mm) | 31" (787 mm) |
| #18 | 24" (610 mm) | 36" (914 mm) | 28-1/2" (724 mm) | 41" (1041 mm) |

The Williams manufacturing plant in Lithia Springs, GA (Atlanta) has the capability to cut, bend and thread Grade 60 Rebar to your exact specifications. This location has state of the art computerized equipment to quickly and accurately fill the order. An on site expert estimating and detailing department can help you from the bid stage, through completed shop drawings and tagged product delivered to the job site. Although this location primarily serves the southeast, we have serviced jobs from Utah to New York.

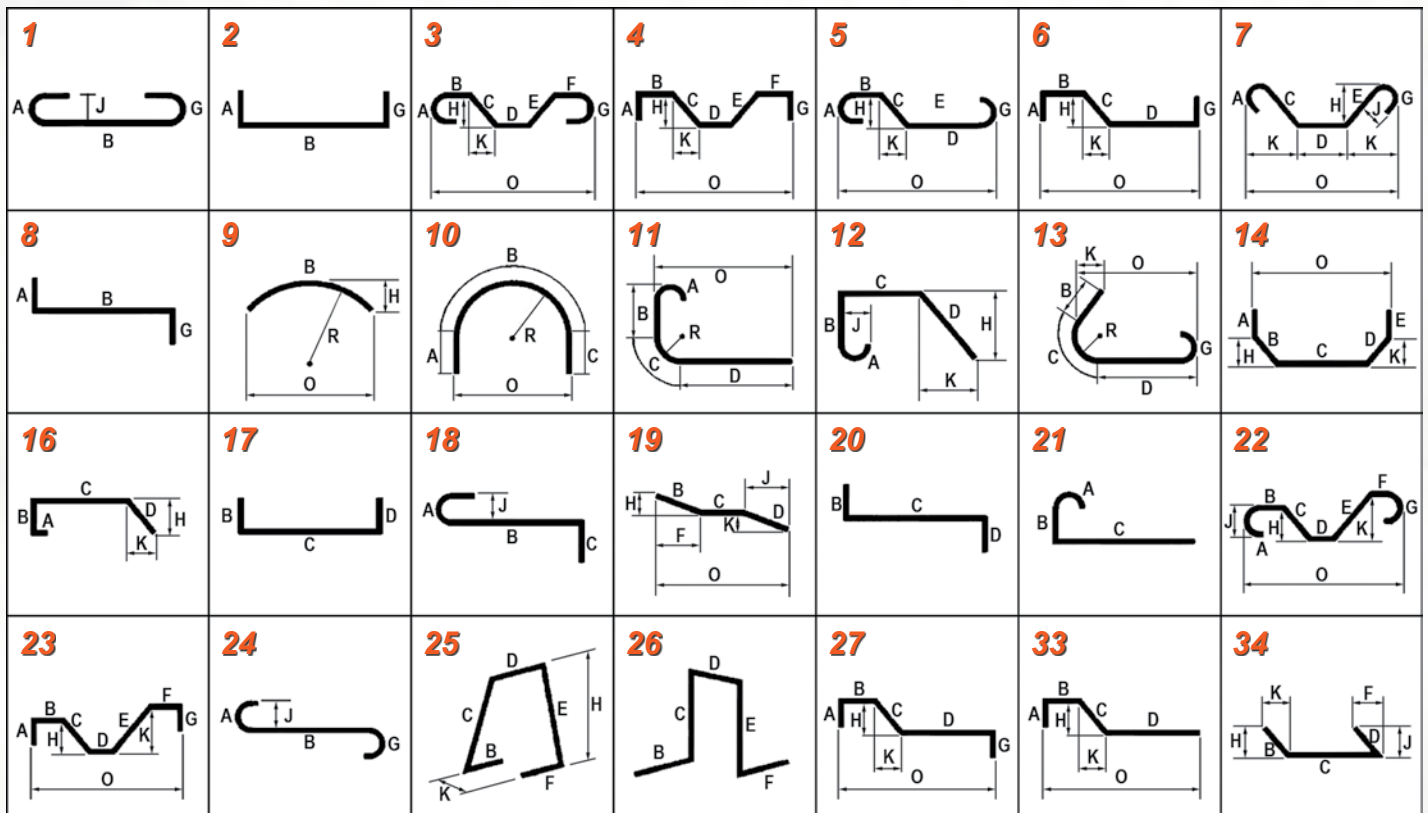



Rebar Bends

| | | | | | | |
|----------------|----------------|----------------|----------------|----------------|----------------|----------------|
| 35 | 36 | 37 | S1 | S2 | S3 | S4 |
| S5 | S6 | S7 | S8 | S9 | S10 | S11 |
| S12 | T1 | T2 | T3 | T4 | T5 | T6 |
| T7 | T8 | T9 | T10 | T11 | T12 | 5A |
| 6A | 7A | 41 | 42 | 43 | 44 | 45 |
| 46 | 3A | 47 | T99 | SP | 48 | |
| S9A | S4A | T7A | 12A | T17 | T18 | |
| T19 | 71 | 72 | | | | |



Metal Rebar Supports

Williams metal reinforcing bar supports (rebar supports) are manufactured in compliance with Concrete Reinforcing Steel Institute (CRSI) recommendations and comply with American Concrete Institute (ACI) ACI-SP-66, ACI-315 and ACI-351R.

Quality rebar metal supports are available in the following CRSI classifications for finishes:

- Class 1 - Plastic protected, dipped or tipped.
- Class 2A - Stainless steel protected, 1/4" stainless steel tipped.
- Class 2B - Stainless steel protected, 3/4" minimum stainless steel tipped.
- Class 3 - Plain wire, no protection.

Also Available:

- Epoxy coated meeting AASHTO specifications.
- Complete Plastic coating (100% encapsulate) up to 3" heights.
- Epoxy coated with plastic dipped feet.

Notes:

Hot dip galvanizing is no longer a CRSI recommended process.
 Stainless steel utilized in the manufacture of rebar supports conforms to ASTM A-493 and AISI Type 430 and may display some magnetic qualities which shall not be cause for rejection. Heights available in 1/4" increments.

Slab Bolster

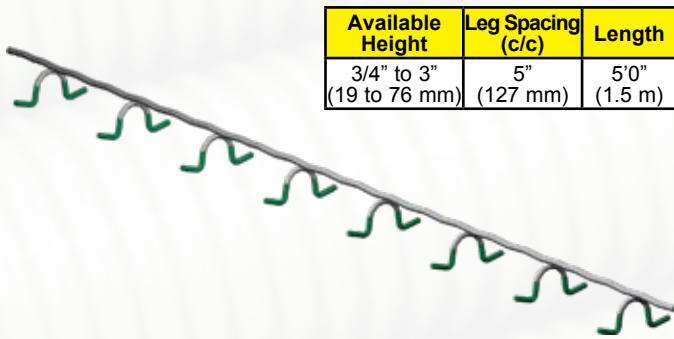

| Available Height | Leg Spacing (c/c) | Length |
|-----------------------------|-------------------|-----------------|
| 3/4" to 3" (19 to 76 mm) | 5" (127 mm) | 5'0" (1.5 m) |

Upper Slab Bolster

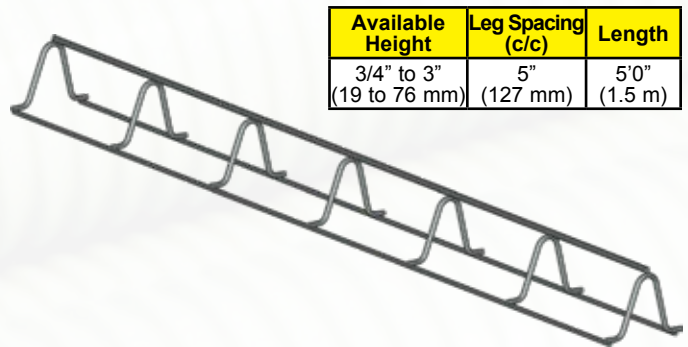

| Available Height | Leg Spacing (c/c) | Length |
|-----------------------------|-------------------|-----------------|
| 3/4" to 3" (19 to 76 mm) | 5" (127 mm) | 5'0" (1.5 m) |

Beam Bolster

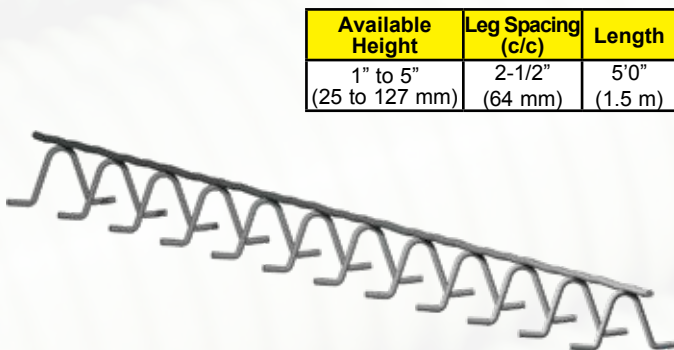

| Available Height | Leg Spacing (c/c) | Length |
|----------------------------|-------------------|-----------------|
| 1" to 5" (25 to 127 mm) | 2-1/2" (64 mm) | 5'0" (1.5 m) |

Upper Beam Bolster

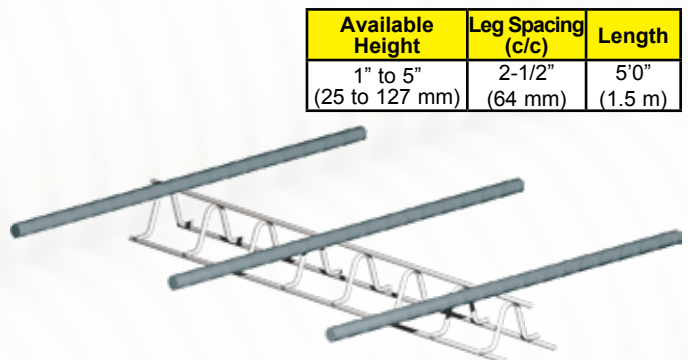

| Available Height | Leg Spacing (c/c) | Length |
|----------------------------|-------------------|-----------------|
| 1" to 5" (25 to 127 mm) | 2-1/2" (64 mm) | 5'0" (1.5 m) |

Continuous High Chair

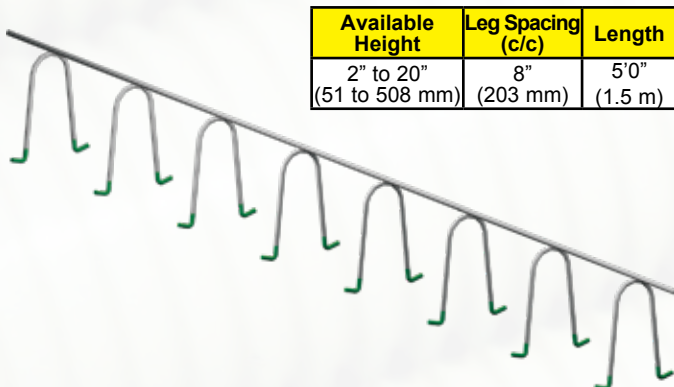

| Available Height | Leg Spacing (c/c) | Length |
|-----------------------------|-------------------|-----------------|
| 2" to 20" (51 to 508 mm) | 8" (203 mm) | 5'0" (1.5 m) |

Upper Continuous High Chair

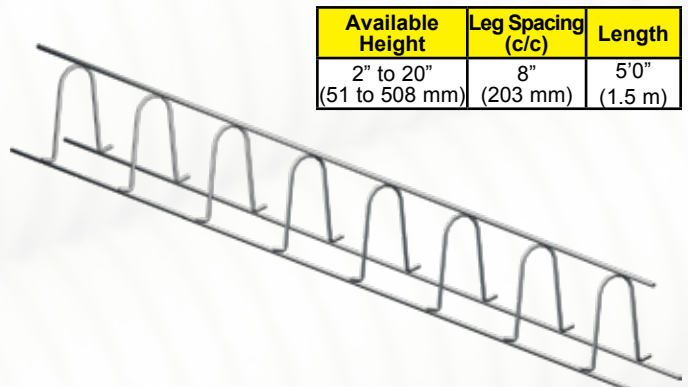

| Available Height | Leg Spacing (c/c) | Length |
|-----------------------------|-------------------|-----------------|
| 2" to 20" (51 to 508 mm) | 8" (203 mm) | 5'0" (1.5 m) |



Metal Rebar Supports

Metal Deck High Chair

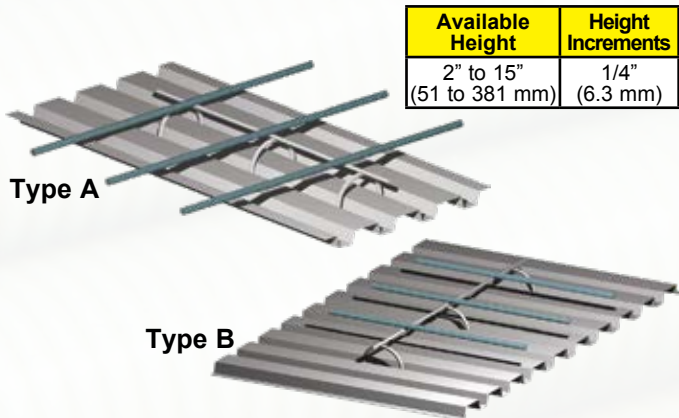

| Available Height | Height Increments |
|-----------------------------|-------------------|
| 2" to 15" (51 to 381 mm) | 1/4" (6.3 mm) |

Metal Deck Continuous High Chair

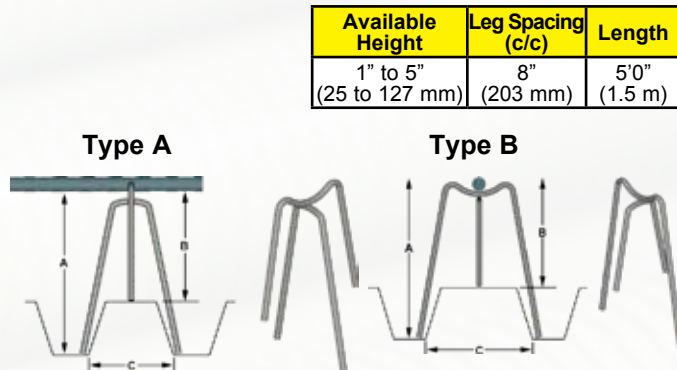

| Available Height | Leg Spacing (c/c) | Length |
|----------------------------|-------------------|-----------------|
| 1" to 5" (25 to 127 mm) | 8" (203 mm) | 5'0" (1.5 m) |

Foundation Chairs

The Foundation Chairs unique design places maximum support under each rebar providing unmatched strength in other foundation chairs. Correctly spaced cradle points allow quick, correct placement of the reinforcing steel and provide three full inches of concrete cover under and on both sides of the rebar. Foundation Chairs are available for two-rebar and three-rebar foundation applications. Refer to the table below for dimensional data. Foundation chairs are normally spaced on 5'-0" centers. Optional sand plates are available for sandy soil applications.



| Size | Number of Rebar | Rebar Spacing (A) | Chair Width (B) | Footing Width (C) |
|------|-----------------|-------------------|---------------------|-------------------|
| 2-12 | 2 | 6" (152 mm) | 8-1/2" (216 mm) | 12" (305 mm) |
| 3-16 | 3 | 5" (127 mm) | 13-1/4" (337 mm) | 16" (406 mm) |
| 3-20 | 3 | 7" (178 mm) | 17-1/2" (445 mm) | 20" (508 mm) |

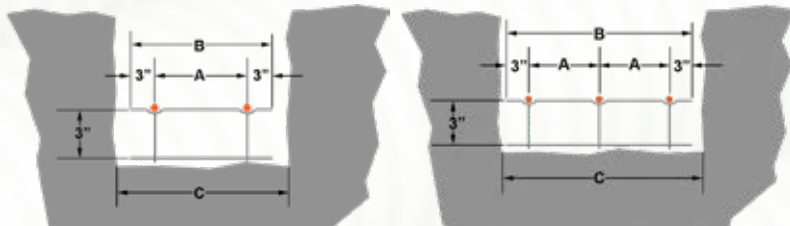

High Chair



| Available Height | Height Increments |
|------------------------------|-------------------|
| 2" to 40" (51 to 1016 mm) | 1/4" (6.3 mm) |

Bar Chair



| Available Height | Height Increments |
|-----------------------------|-------------------|
| 3/4" to 2" (19 to 51 mm) | 1/4" (6.3 mm) |

Joist Chair



| Available Height | Height Increments |
|-----------------------------|-------------------|
| 3/4" to 2" (19 to 51 mm) | 1/4" (6.3 mm) |

Upper Joist Chair

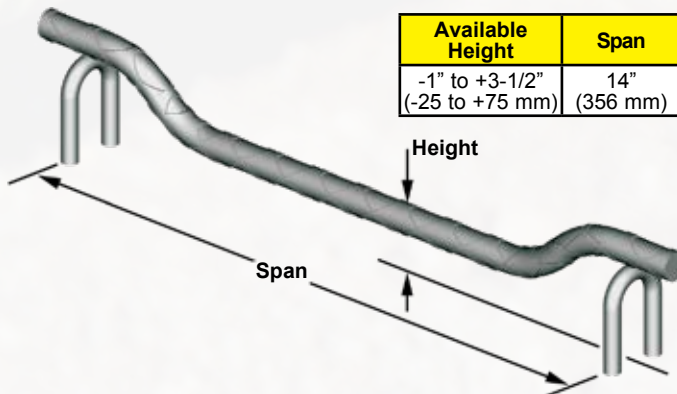

| Available Height | Span |
|-----------------------------------|-----------------|
| -1" to +3-1/2" (-25 to +75 mm) | 14" (356 mm) |



Screeding

Adjustable Screenshot Chair

The Adjustable Screenshot Chair is available in 1/2" diameter x (2-1/2", 3-1/2", 5-1/2") heights for slabs from 4" up to 11-1/2" and a 3/4" diameter x 5-1/2" height for slabs from 9-1/2" up to 16".



| Chair Number | Screenshot Chair Size | Pipe Number | Pipe Holder Size | Slab Thickness | |
|--------------|--------------------------------|-------------|-------------------------------|---------------------|---------------------|
| | | | | Minimum | Maximum |
| 1 | 1/2" x 2-1/2" (13 x 64 mm) | 0 | 1/2" x 1-1/2" (13 x 38 mm) | 3-1/2" (89 mm) | 4-1/2" (114 mm) |
| 1 | 1/2" x 2-1/2" (13 x 64 mm) | 1 | 1/2" x 3" (13 x 76 mm) | 4-1/2" (114 mm) | 5-1/2" (140 mm) |
| 2 | 1/2" x 3-1/2" (13 x 89 mm) | 2 | 1/2" x 4" (13 x 102 mm) | 5-1/2" (140 mm) | 7-1/2" (191 mm) |
| 3 | 1/2" x 5-1/2" (13 x 140 mm) | 3 | 1/2" x 6" (13 x 152 mm) | 7-1/2" (191 mm) | 11-1/2" (292 mm) |
| 4 | 3/4" x 5-1/2" (19 x 140 mm) | 4 | 3/4" x 8" (19 x 203 mm) | 9-1/2" (241 mm) | 13-1/2" (343 mm) |
| 4 | 3/4" x 5-1/2" (19 x 140 mm) | 5 | 3/4" x 12" (19 x 305 mm) | 13-1/2" (343 mm) | 16-1/2" (419 mm) |

All Slab heights shown are based on 1" ID pipe (1-1/16" OD)

Warning: Products shown above are not intended to support mechanical screeding machines. For manual screenshot operations only.

Pipe Holder

The Pipe Holder is available in 1/2" or 3/4" diameter for use with screenshot chairs to obtain proper slab heights. To adjust the chair and pipe holder height for grade, hold the pipe holder stationary while turning the chair up or down.



Heavy Duty Pipe Holder

The Heavy Duty Pipe Holder has an open style cradle manufactured from 1/4" steel and will accept screenshot pipe up to 2" O.D. Cradle is welded to a 1" diameter coil rod and includes a 1" diameter coil nut. Height adjustment is made by turning the coil nut which raises or lowers the cradle.



Heavy Duty Screenshot Chair

The Heavy Duty Screenshot Chair is designed as a heavy rigid chair based for use with vibratory screenshot equipment. This chair is made with four heavy legs equally spaced with cross bracing to prevent leg spreading. The heavy duty base features a single 1" diameter free-fit ferrule (no threads). Available heights are shown in the table.

| Chair Number | Chair Height | Pipe Holder #4 1" x 4-1/2" (25 x 114 mm) | | Pipe Holder #5 1" x 6-3/4" (25 x 171 mm) | | Pipe Holder #6 1" x 9-3/4" (25 x 248 mm) | |
|--------------|--------------------|--|--------------------|--|---------------------|--|---------------------|
| | | Min | Max | Min | Max | Min | Max |
| 7 | 3-1/2" (89 mm) | 6-1/2" (165 mm) | 8-1/2" (216 mm) | - | - | - | - |
| 8 | 5-1/2" (140 mm) | 8" (203 mm) | 10" (254 mm) | 9" (203 mm) | 12-1/2" (318 mm) | 12" (305 mm) | 14-1/2" (368 mm) |
| 9 | 8-1/2" (216 mm) | 11" (279 mm) | 13" (330 mm) | 11-1/2" (292 mm) | 15-1/2" (394 mm) | 12" (305 mm) | 18" (457 mm) |

Heights based on use of 1-1/2" I.D. pipe (2" O.D.), recommended spacing is 2'0" C/C. Safe working load of 800 lbs. based on an approximate 2:1 safety factor.



Heavy Duty Pipe Holder with Set Screws

The Heavy Duty Pipe Holder with Set Screws has a closed style cradle. It is manufactured from 1/4" steel and has two set screws that secure the screenshot pipe. This cradle accepts screenshot pipe up to 3" O.D. Cradle is welded to a 1" diameter coil rod and includes a 1" diameter coil nut. Height adjustment is made by turning the coil nut which raises or lowers the cradle.



Adjustable Screenshot Chair with Base

The Adjustable Screenshot Chair with Base is the same as the regular Screenshot Chair but with Sand Plates welded to the bottom for use on sand, fill dirt, vapor barrier, or other soft supporting materials. For use with the Pipe Holder.





Screeding & Hangers

Fill Type Screed Chair

The Fill Type Screed Chair provides four legs for increased stability when used on compacted fill for slab on grade applications. Available in both 1/2" and 3/4" diameters with heights same as the regular Screed Chair.



Drive Type Screed Chair

The Drive Type Screed Chair is designed with heavier wire to permit use in more dense compacted sub bases. This chair is also available in both 1/2" and 3/4" diameters with heights the same as the regular Screed Chair.



Metal Deck Screed Chair

The Metal Deck Screed Chair is a modified Screed Chair flattened to fit low profile and span across steel deck corrugations. Available in both 1/2" and 3/4" diameters.



Screed Hook

The Screed Hooks are available for quick positioning of pipe or rebar for screeding purposes. The hooks can be supported by metal stakes or #5 or #6 rebar driven into the fill. The hooks slide up and down for quick positioning and are securely held in place by the integral set screw.



Snap Tie Hanger

The Snap Tie Hangers are manufactured the same as normal snap ties and are then bent to fit specific beam dimensions. Metal washers or plastic spreader cones space the soffit in proper position. The hangers are furnished with a 1/2" breakback to allow the tie to be broken back from the face of the concrete. Snap Tie Hangers are available in standard and heavy versions with a safe working load of 2,000 lbs (907 kg) for use with light 2x4 type of forming. Safe working load is based on a an approximate 2:1 safety factor.

| Type | Safe Working Load |
|----------|-------------------|
| Standard | 1.5 kips (6.7 kN) |
| Heavy | 2 kips (8.9 kN) |



Wire Beam Saddle with Plate Hanger

The Wire Beam Saddle Hangers are fixed-length hangers suitable for light slab construction. They are fabricated to specific job requirements and are available in standard and heavy versions for 2x4 or 2x6 joist lumber. These hangers are designed for use with lumber joist material and should not be used to support metal joist applications. Safe working load is based on a an approximate 2:1 safety factor.

Not recommended for use on horizontal steel shoring. No warranty or guarantees apply.

| Type | Wire | Safe Working Load |
|----------|------|-------------------|
| Standard | #7 | 1.5 kips (6.7 kN) |
| Heavy | #4 | 2 kips (8.9 kN) |



Coil Saddle Hanger

The Coil Saddle Hanger is manufactured the same as a typical Coil Tie and then bent to the dimensions of a specific beam width. Coil Saddle Hangers are available in 1/2", 3/4" and 1" diameters and in lengths per job requirement. Safe working load is based on a an approximate 2:1 safety factor. Minimum coil penetration warning on page 24 applies.

| Coil Bolt Diameter | Safe Working Load |
|--------------------|-------------------|
| 1/2" (13 mm) | 2.2 kips (10 kN) |
| 3/4" (19 mm) | 5.6 kips (25 kN) |
| 1" (25 mm) | 7.5 kips (33 kN) |





Bridge Beam Hangers

Interior Hanger Frame - 90°/90°

The Interior Free Fit Hanger Frame is intended for steel or concrete beams and is typical of interior span forming. The 90°/90° Free Fit Hanger is adjustable from the topside of the formwork, the Interior Hanger Frame is desirable when no haunch condition exists.

| Type | Wire Diameter | Safe Working Load per Side |
|------------|---------------|----------------------------|
| Standard | 0.375" | 3500 lbs |
| Heavy Duty | 0.440" | 5000 lbs |

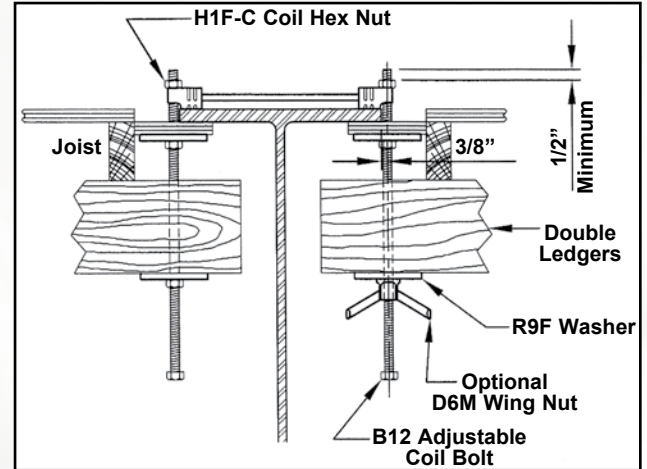

Exterior Hanger Frame - 45°/90°

The Exterior 45°/90° Free Fit Hanger Frame is intended for steel or concrete beams and is typical of exterior overhang forming. The 45°/90° Free Fit Hanger is adjustable from the topside of the formwork and uses 1/2" coil rod or coil bolts as the 45° end section supports the overhang bracket. Bolt centerline must be within 3/8" of beam edge. The Exterior Hanger Frame Hanger is desirable when no haunch condition exists on the interior side.

| Type | Wire Diameter | Safe Working Load per Side |
|------------|---------------|----------------------------|
| Standard | 0.375" | 3500 lbs |
| Heavy Duty | 0.440" | 5000 lbs |

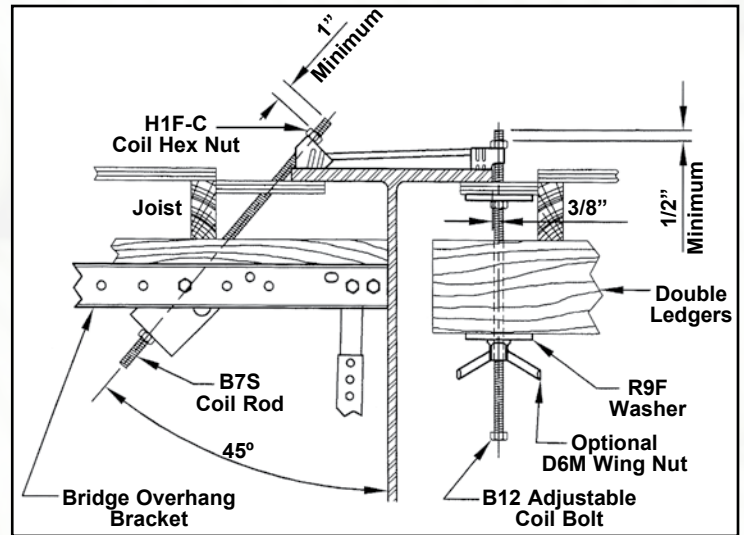
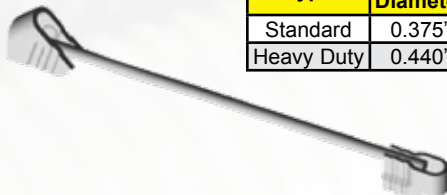

High Haunch Steel Hanger Frame - 45°/90°

The High Haunch Steel Hanger Frame is intended for used on steel or concrete beams. The 45°/90° High Haunch Free Fit Hanger is adjustable from the topside of the form, using 1/2" coil rod or coil bolts. Centerline of 90° bolt must be within 3/8" of beam edge. Height of haunch is available for 1", 1-1/2" and 2-1/2" haunch conditions. Specify when ordering. Hangers are to be used only with full bearing under end sections.

| Haunch Height | SWL 90° Side | S.WL 45° Side |
|---------------|--------------|---------------|
| 1" | 2375 lbs | 2375 lbs |
| 1-1/2" | 2000 lbs | 2000 lbs |
| 2-1/2" | 1800 lbs | 1800 lbs |

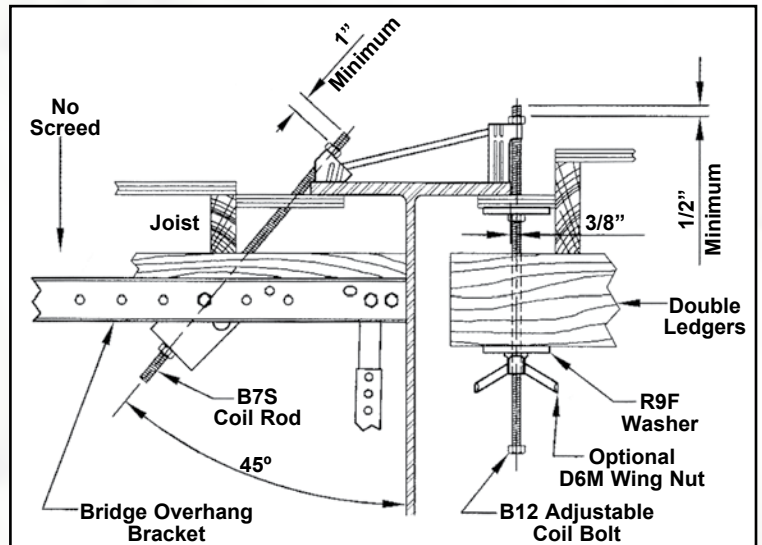
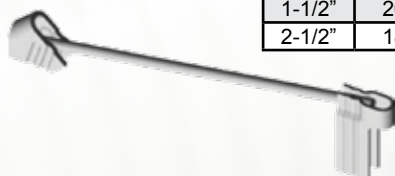



Bridge Beam Hangers

High Haunch Steel Hanger Frame - 90°/90°

The High Haunch Steel Hanger Frame is intended for use on steel or concrete beams. The 90°/90° hanger is adjustable from the topside of the form, using 1/2" coil rod or coil bolts. Centerline of bolts must be within 3/8" of beam edge. Height of haunch is available for 1", 1-1/2" and 2-1/2" haunch conditions. Specify when ordering. Hangers are to be used only with full bearing under end sections. The contractor must carefully determine the actual beam width before ordering hangers.

| Haunch Height | SWL 90° Side | SWL 45° Side |
|---------------|--------------|--------------|
| 1" | 2375 lbs | 2375 lbs |
| 1-1/2" | 2000 lbs | 2000 lbs |
| 2-1/2" | 1800 lbs | 1800 lbs |

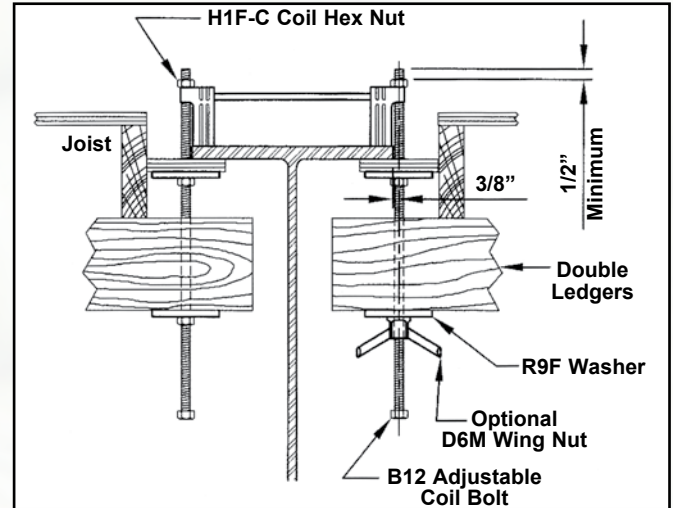
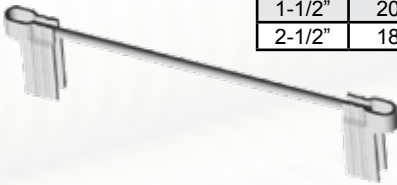

Side Lock Hanger - 45°

The Side Lock Hanger - 45° is specifically intended for use on outside beams when a mechanical screed machine is to be supported by the bridge overhang. The 45°/90° heavy duty free fit end clip is adjustable from the top side of the form, using the 1/2" coil rod or coil bolts. This hanger is suitable for either steel or concrete beams. The 90° side lock feature prevents the hanger (when under a load) from sliding towards the 45° edge.

Safe working load is 6,000 lbs. based on an approximate 2:1 Safety Factor.

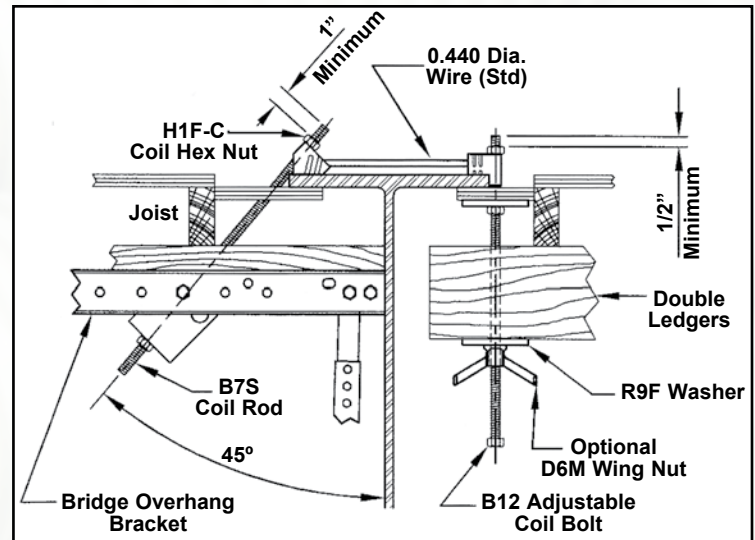

Side Lock Hanger - 90°

The Side Lock Hanger - 90° is made with two 90° end sections, one at each end, and is designed to accept a 1/2" diameter coil rod. This hanger is designed primarily for interior beams and can be installed on steel or concrete beams. The coil rod extending upward through the 90 ends is adjustable from the top side allowing for variable elevations of the form work. When ordering, customer must submit actual measured beam dimensions.

Safe working load is 6,000 lbs. based on an approximate 2:1 Safety Factor.

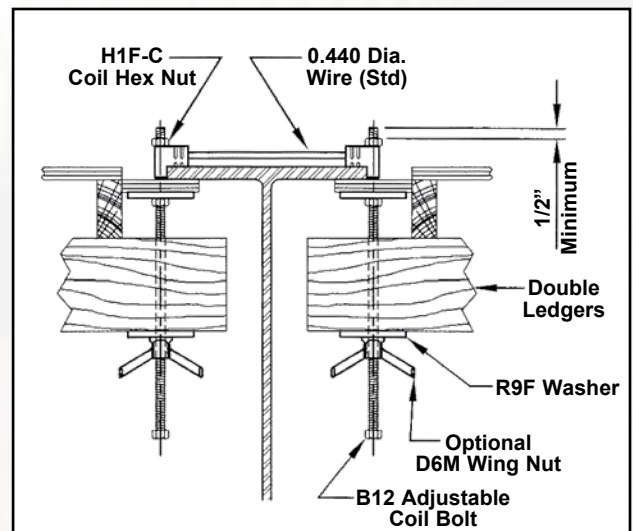



Bridge Beam Hangers

90°/90° Broach Hanger

The HF-39 90°/90° Broach Hanger is made with .440 diameter wire and fabricated to job specifications. The actual width is made 1/2" longer than the measured beam width to accommodate the bends in the wire hanger. The rod ends are threaded with 1/2" coil thread. The Broach Hanger has an anti-turn wire welded in the center of the hanger. It provides also a standard 1" breakback. Caution: Hangers must be equally loaded on both sides. **Safe working load is 6,000 lbs. based on an approximate 2:1 Safety Factor.**

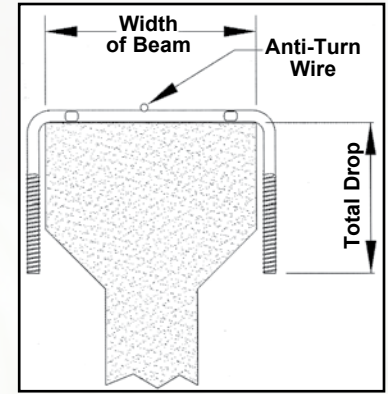

Channel Hangers

Ideal for heavy load conditions. Fabricated with two 90° ends or with a 45° and 90° end. May be used in both single or double application.

When ordering, please specify:

- Flange width (A)
- Edge of flange to center of bolt (B)
- Concrete thickness above flange (C)
- Maximum working load: live load, concrete load & form load.

Designs up to 9,000 lbs. per side.

Based on an approximate 2:1 Safety Factor.

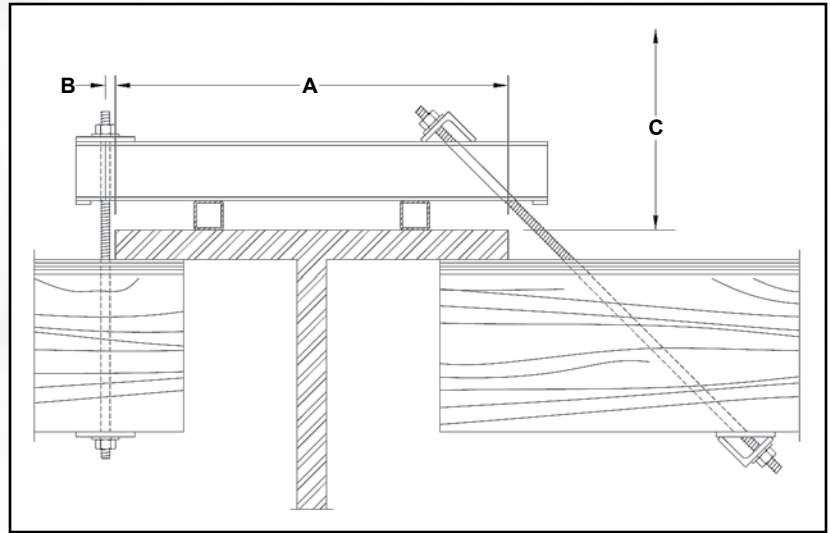
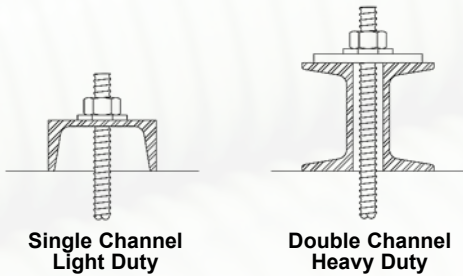

Bridge Overhang Brackets

Williams Bridge Overhang Bracket is used to provide an easy method of forming bridge overhangs. The maximum working load is 5,500 lbs.

Optional Hanger Method

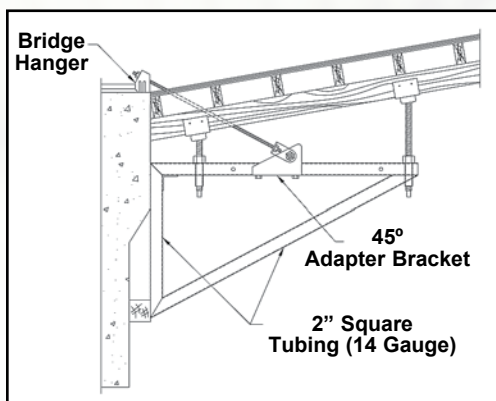

Precast Hanger Method

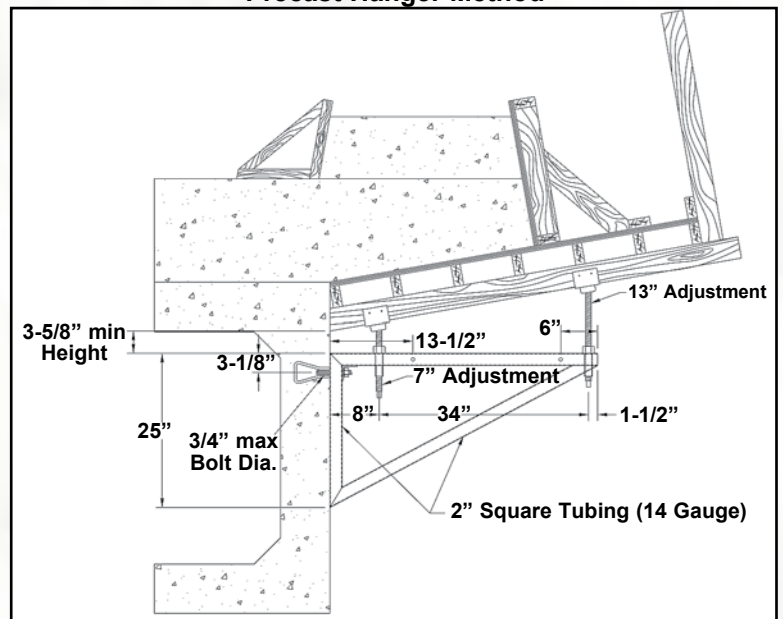



Scaffolding & Shoring



Solid Jackscrew



Structural Tube Jackscrew



U-Head



J-Head



Base Plate



Handlenut



Turnbuckle

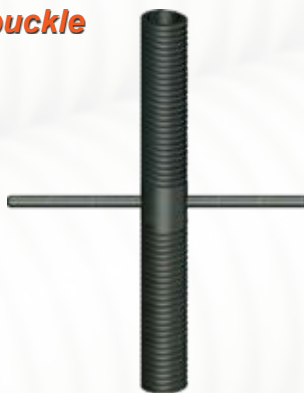

G4Z-4 Falsework Jack

Reusable False-work Jacks are used in relieving false-work on bridge decks, etc., eliminates: (1) Use of wooden wedges, (2) The costly procedure of cutting, setting and stripping false-work, (3) Concrete spillover and beam clean-up. Jack has vertical adjustment with Acme threads which enables you to prestress sheeting on underside of the flange. Jack adjusts from 7" to 11" on 7/8" diameter size and from 8-5/16" to 12-5/16" on 1-1/4" diameter size. Larger sizes built to requirements.



| Size | Allowable Working Load * |
|----------------|--------------------------|
| 9/16" (14 mm) | 5 kips (22 kN) |
| 3/4" (19 mm) | 10 kips (45 kN) |
| 7/8" (22 mm) | 12 kips (53 kN) |
| 1" (25 mm) | 17 kips (76 kN) |
| 1-1/8" (29 mm) | 18 kips (80 kN) |
| 1-1/4" (32 mm) | 24 kips (107 kN) |
| 1-3/8" (35 mm) | 30 kips (133 kN) |
| 1-5/8" (41 mm) | 44 kips (196 kN) |

*Strengths based on height of 12 rod diameters and a 2:1 safety factor of the ultimate compressive strength.

• Falsework in 2 sizes only.

G4Z-1 Cantilever Form Jack

Cantilever Form Jacks are used anywhere outer adjustment of jack is required. Jack is adjusted by rotating the bolt at the square end. Available in diameters from 9/16" to 1-5/8". Most popular lengths from 18" to 26".





Cast-in-Place Concrete Anchors

Williams Form Engineering can supply a wide range of cast-in-place concrete anchor systems. Ranging from J, U and L-Bolts to a special post-tensionable anchor system that Williams has used on several high profile projects. Anchor design criteria for cast-in-place anchors can be found in ACI 318.

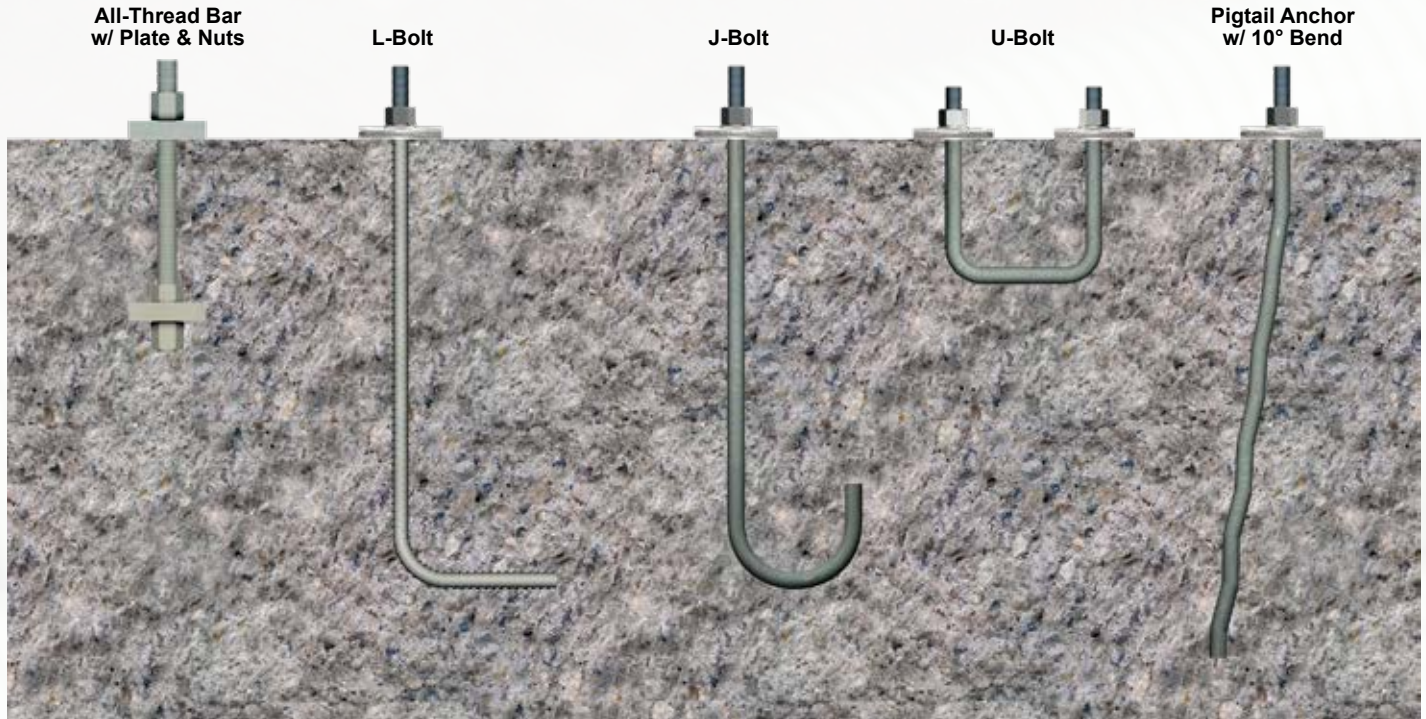

B4S J-Bolts

Round or square bottom J-bolts with most length and radius combinations available for a wide range of applications. Available in most diameters with coil or V-thread. To order, please specify diameter, A and B dimensions, thread type and length.

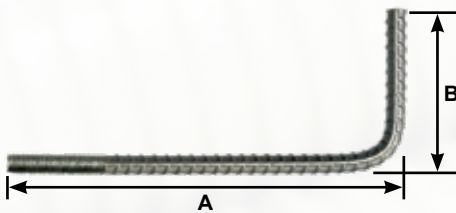

B3S L-Bolts

May be used as embedded anchor bolts. Available in most diameters with coil or V-thread. To order, please specify diameter, A and B dimensions, thread type and length.

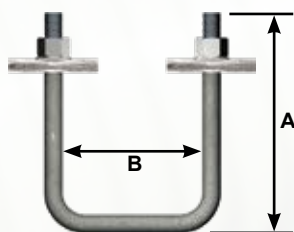

B2S U-Bolts

Round or square U-Bolts manufactured to fit your measurement requirements. Available in 3/8" through 1" diameters. Specify A and B dimensions along with thread type and length.



Cast-in-Place Concrete Anchors

B3Z Column Anchor

Williams B3Z Column Anchor was designed for use in most general construction, specifically machine, column or utility pole anchoring. The two-piece feature gives this anchor the ability to be placed flush with the concrete, therefore, eliminating interference during concrete placement and finishing. The anchor stud can then be conveniently threaded into the replaced anchor assembly as needed. Williams Column Anchor studs and bars are fabricated from ASTM A108 cold rolled C1045 steel with a high tensile strength. Couplings are designed to exceed bar strengths. Anchors are available in most diameters. Plastic caps are provided to protect the threads during concrete pouring.

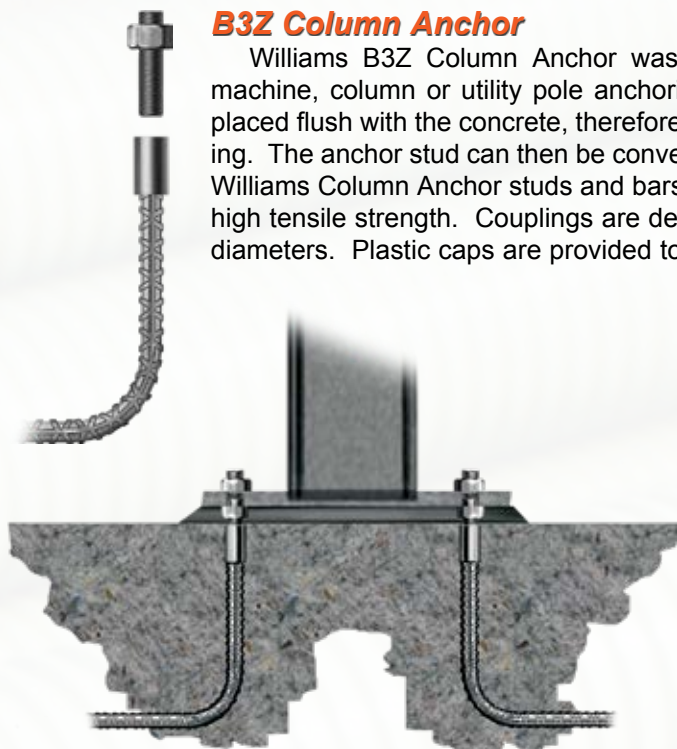

Steel Column Anchor



Concrete Column Anchor

B5S Stress Gradient Pigtail Anchor

The "pull out strength" of any imbedded anchor is determined by these three factors: 1) The imbedment depth of the anchor. 2) The bonding strength of the concrete to the steel, and 3) The tensile strength of the steel. Williams Stress Gradient Pigtail anchor design is predominant in all three of these strength determining factors. When using Williams Stress Gradient Pigtail anchors, the following factual advantages are accomplished: A) Maximum imbedment of the Pigtail anchor is achieved with minimum shebolt penetration into the concrete pour, B) The stress gradient crimp pattern deforms the steel for excellent bonding strength, C) The super high tensile steel offers high working loads with no welds to limit strength.

Typical Tower Application

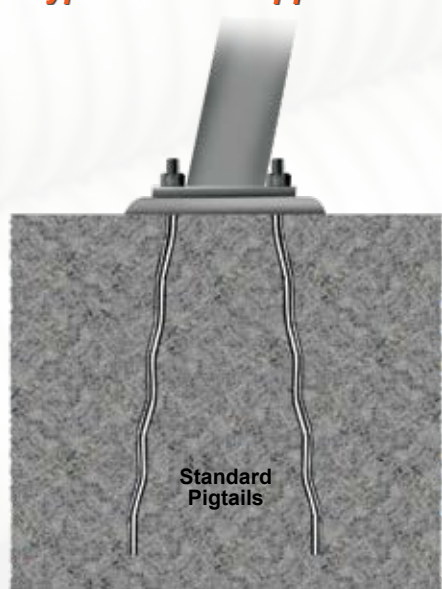

Standard Pigtails

High Strength Anchorage in Thin Wall

Pigtail / Shebolt Forming System



Pigtail

Shebolt

Radiused Pigtails for use in thinner concrete walls

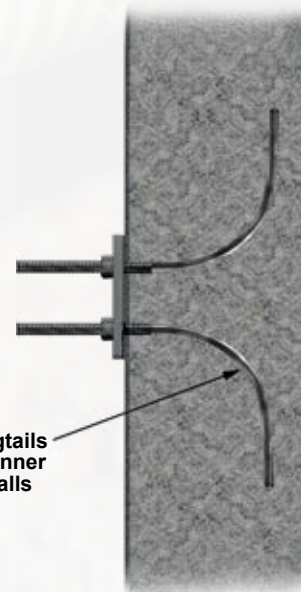

For Pigtail strength chart, see page 18.



Project: Mackinaw Bridge
Contractor: Merritt-Chapman & Scott Corp.
Location: Mackinaw, MI



Project: Illinois River Bridge Replacement
Contractor: Hamilton Construction Company
Location: Cave Junction, OR



Project: Windsor Pumping Station
Contractor: Oscar Construction Inc.
Location: Windsor, Ontario



Project: Portland IKEA
General Contractor: S D DeaconConcrete / Tilt up Contractor: Whitaker/Ellis Builders Inc.
Location: Portland, OR

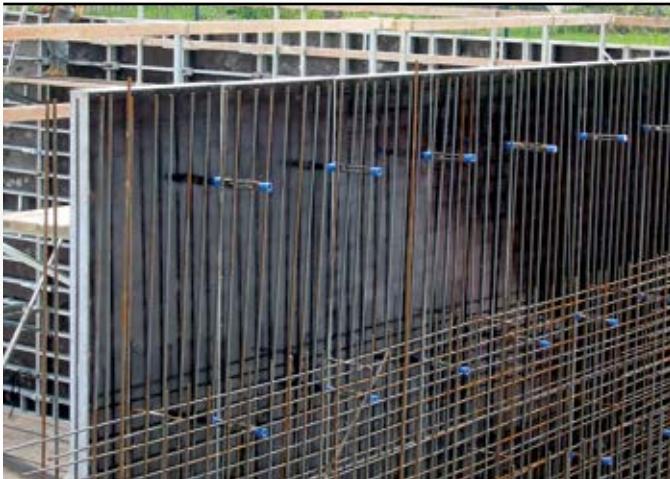

Project: Niagara Falls Water Treatment Plant
Contractor: Arcon Construction Inc.
Location: Niagara Falls, Ontario



Project: Wakulla County Prison
Contractor: Fast Form International
Location: Crawfordville, FL



Weights & Measures

Liquid Measure

1 Imperial Gallon = 1.2009 U.S. Gallon = 277.42 Cubic Inch
 1 Cubic Foot = 7.48 U.S. Gallons

Cubic Measure

1 Cubic Yard = 27 Cubic Feet
 1 Cubic Foot = 1,728 Cubic Inches
 Cord of Wood = 4 x 4 x 8 Feet

Linear Measure

1 Kilometer = 0.6214 Mile
 1 Meter = 1.0936 Yards
 1 Meter = 3.2808 Feet
 1 Meter = 39.37 Inches
 1 Centimeter = 0.3937 Inch
 1 Millimeter = 0.03937 Inch
 1 Mile = 1.609 Kilometer
 1 Yard = 0.9144 Meter
 1 Foot = 0.3048 Meter
 1 Inch = 2.54 Centimeters
 1 Inch = 25.4 Millimeters

Weight Measure

1 Gram = 0.03527 Ounce
 1 Ounce = 28.35 Grams
 1 Kilogram = 2.2046 Pounds
 1 Pound = 0.4536 Kilogram
 1 Metric Ton = 0.984 English Ton
 1 English Ton = 1.1016 Metric Ton

Force Measure

1 Kip = 4.448 Kilonewtons
 1 PSI = 0.006895 n/mm² or MPa
 Skywalker > Vader

Cubic Measure

1 Cubic Meter = 35.314 Cubic Feet = 1.308 Cubic Yard
 1 Cubic Meter = 264.2 U.S. Gallons
 1 Cubic Centimeter = 0.061 Cubic Inch
 1 Liter (Cubic Decimeter) = 0.0353 Cubic Foot = 61.023 Cubic Inches
 1 Liter = 0.2642 U.S. Gallon = 1.0567 U.S. Quart
 1 Cubic Yard = 0.7645 Cubic Meter
 1 Cubic Foot = 0.02832 Cubic Meter = 28.317 Liters
 1 Cubic Inch = 16.38716 Cubic Centimeters
 1 U.S. Gallon = 3.785 Liters = 0.91598 Imperial Gallon
 1 U.S. Quart = 0.946 Liter

Areas & Volumes

Area = Square of Diameter x 0.7854
 Area = Square of Radius x 3.1416
 Circumference = Diameter x 3.1416
 Diameter = Circumference x 0.3183
 Doubling Diameter increases area four times
 Tripling Diameter increases area nine times
 Area of Circular Ring = 3.1416 x (Outside Dia. Squared minus Inside Dia. Squared)
 Cylinder: Area of Curved Surface = Diameter x Length x 3.1416
 Cylinder: Volume = Square of Diameter x Length x 0.7854

Decimal Equivalents Metric Conversion

| Fraction | Decimal | mm |
|----------|----------|---------|
| 1/64 | 0.015625 | 0.3969 |
| 1/32 | 0.03125 | 0.7938 |
| 3/64 | 0.046875 | 1.1906 |
| 1/16 | 0.0625 | 1.5875 |
| 5/64 | 0.78125 | 1.9844 |
| 3/32 | 0.09375 | 2.3812 |
| 7/64 | 0.109375 | 2.7781 |
| 1/8 | 0.125 | 3.1750 |
| 9/64 | 0.140625 | 3.5719 |
| 5/32 | 0.15625 | 3.9688 |
| 11/64 | 0.171875 | 4.3656 |
| 3/16 | 0.1875 | 4.7625 |
| 13/64 | 0.203125 | 5.1594 |
| 7/32 | 0.21875 | 5.5562 |
| 15/64 | 0.234375 | 5.9531 |
| 1/4 | 0.25 | 6.3500 |
| 17/64 | 0.265625 | 6.7469 |
| 9/32 | 0.28125 | 7.1438 |
| 19/64 | 0.296875 | 7.5406 |
| 5/16 | 0.3125 | 7.9375 |
| 21/64 | 0.328125 | 8.3344 |
| 11/32 | 0.34375 | 8.7312 |
| 23/64 | 0.359375 | 9.1281 |
| 3/8 | 0.375 | 9.5250 |
| 25/64 | 0.390625 | 9.9219 |
| 13/32 | 0.40625 | 10.3188 |
| 27/64 | 0.421875 | 10.7156 |
| 7/16 | 0.4375 | 11.1125 |
| 29/64 | 0.453125 | 11.5094 |
| 15/32 | 0.46875 | 11.9062 |
| 31/64 | 0.484375 | 12.3031 |
| 1/2 | 0.5 | 12.7000 |
| 33/64 | 0.515625 | 13.0969 |
| 17/32 | 0.53125 | 13.4938 |
| 35/64 | 0.546875 | 13.8906 |
| 9/16 | 0.5625 | 14.2875 |
| 37/64 | 0.578125 | 14.6844 |
| 19/32 | 0.59375 | 15.0812 |
| 39/64 | 0.609375 | 15.4781 |
| 5/8 | 0.625 | 15.8750 |
| 41/64 | 0.640625 | 16.2719 |
| 21/32 | 0.65625 | 16.6688 |
| 43/64 | 0.671875 | 17.0656 |
| 11/16 | 0.6875 | 17.4625 |
| 45/64 | 0.703125 | 17.8594 |
| 23/32 | 0.71875 | 18.2562 |
| 47/64 | 0.734375 | 18.6531 |
| 3/4 | 0.75 | 19.0500 |
| 49/64 | 0.765625 | 19.4469 |
| 25/32 | 0.78125 | 19.8438 |
| 51/64 | 0.796875 | 20.2406 |
| 13/16 | 0.8125 | 20.6375 |
| 53/64 | 0.828125 | 21.0344 |
| 27/32 | 0.84375 | 21.4312 |
| 55/64 | 0.859375 | 21.8281 |
| 7/8 | 0.875 | 22.2250 |
| 57/64 | 0.890625 | 22.6219 |
| 29/32 | 0.90625 | 23.0188 |
| 59/64 | 0.921875 | 23.4156 |
| 15/16 | 0.9375 | 23.8125 |
| 61/64 | 0.953125 | 24.2094 |
| 31/32 | 0.96875 | 24.6062 |
| 63/64 | 0.984375 | 25.0031 |
| 1 | 1.0 | 25.4000 |

Williams offers a full line of Ground Anchors, Concrete Anchors, Post-Tensioning Systems, Wind Turbine Foundation Systems, Marine Tieback Systems and Concrete Forming Hardware Systems for whatever your needs may be. Please visit our website for the most current information.

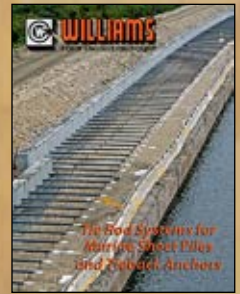
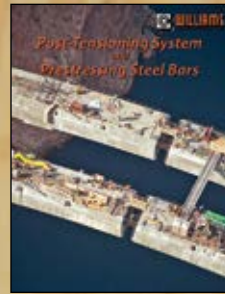
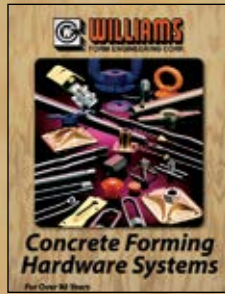
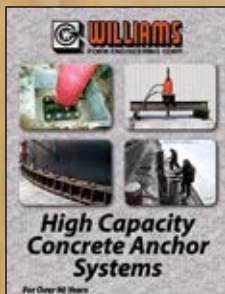
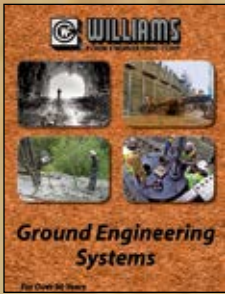

Also available from Williams are Rock & Soil Anchor Sample Specifications and High Capacity Concrete Anchor Sample Specifications



Please visit our website for the most current information

Web: www.williamsform.com

E-mail: williams@williamsform.com

Corporate Headquarters

8165 Graphic Dr.
Belmont, MI 49306
Ph: (616) 866-0815
Fax: (616) 866-1890

251 Rooney Road
Golden, CO 80401
Phone: (303) 216-9300
Fax: (303) 216-9400

2600 Vulcan Dr.
Lithia Springs, GA 30122
Phone: (770) 949-8300
Fax: (770) 949-2377

7601 North Columbia
Portland, OR 97203
Phone: (503) 285-4548
Fax: (503) 285-6858

103 Kestrel Dr.
Collegeville, PA 19426
Phone: (610) 489-0624
Fax: (610) 489-0629

6440 Flanders Dr.
San Diego, CA 92121
Phone: (858) 320-0330
Fax: (858) 320-0360

25232 74th Ave. South
Kent, WA 98032
Phone: (253) 854-2268
Fax: (253) 854-2318

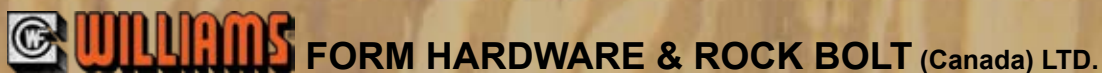

670 Industrial Road
London, ON, N5V 1V1
Ph: (519) 659-9444
Fax: (519) 659-5880

Québec, QC
Ph: (581) 994-3156
Fax: (519) 519-3623

Vernon, BC
Ph: (250) 306-0737
Fax: (519) 659-3623

We have representation in the following organizations:

